

COSCO[®] *f*ITNESS

MOTORIZED TREADMILL

USER'S MANUAL

Model No. Sprint 40

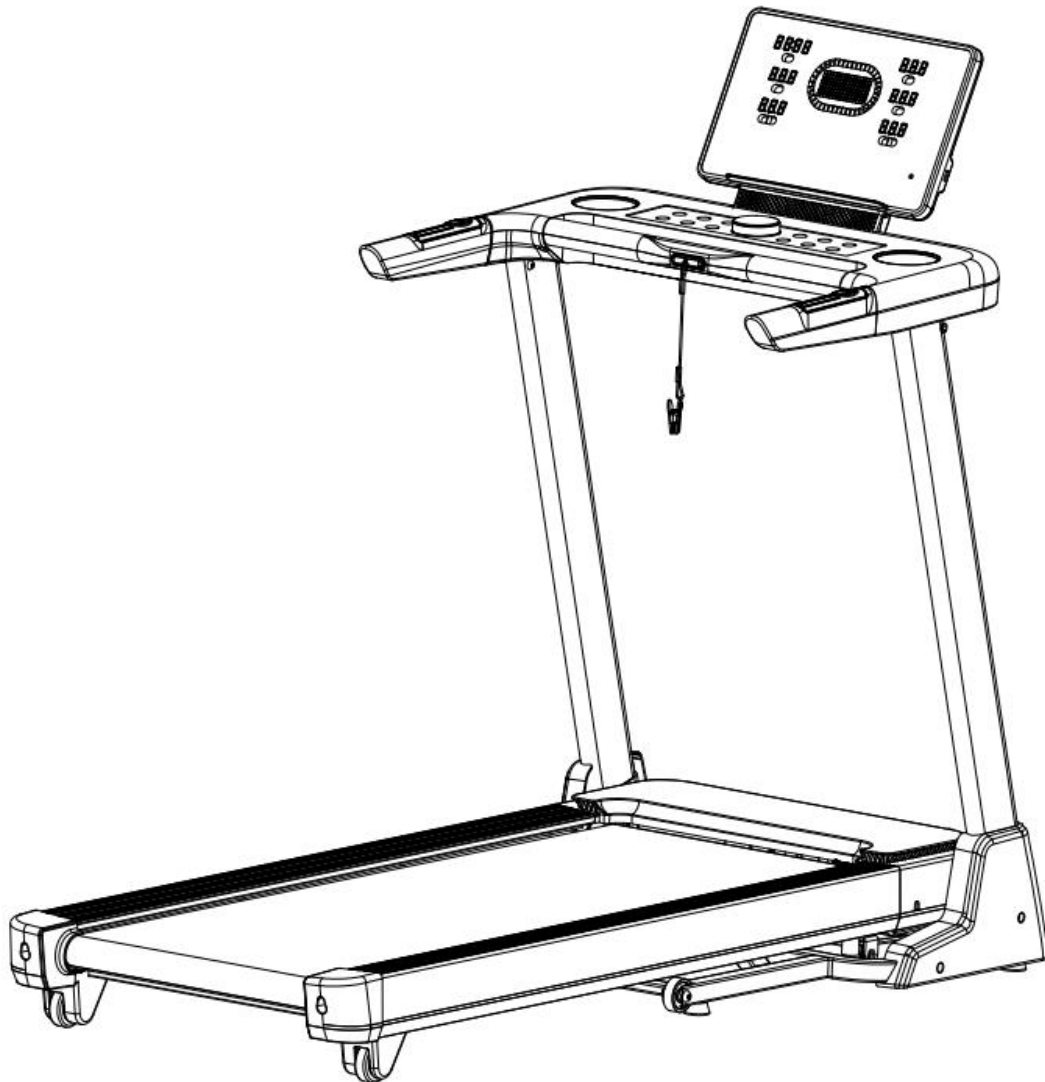

Read all instruction carefully before use
this product. Retain this owner's manual
for the future's reference.

Safety precautions

Warning: We suggest that you should consult with your physician or health professional before starting your workout, especially for the age up to 35 old or health problem related people. We take no responsible for any troubles or hurts if you don't following our specification. Treadmill should be carefully assembled and covered the motor shield, then connect to the power.

Attention :

1. Ensuring the safety clamps were attached to the clothing or belts before using the treadmill.
2. Please do not insert any items to any part of the equipment, which would damage the equipment.
3. Position the treadmill on a clear level surface. Do not place the treadmill on thick carpet as it may interfere with proper ventilation. Do not place the treadmill near water or outdoors.
4. Never start the treadmill while you are standing on the walking belt. After turning the power on and adjusting the speed control, there may be a pause before the walking belt begins to move, always stand on the foot rails on the sides of the frame until the belt is moving.
5. Wear appropriate clothing when exercising on the treadmill. Do not wear long, loose fitting clothing that may be caught in the treadmill. Always wear running or aerobic shoes with rubber soles.
6. Keep the children and pets away from the treadmill while starting workout.
7. Don't exercise in 40-Mints after dinner.
8. The equipment is suitable for adults, Juveniles need be accompanied with adults while workout.
9. You must hold on to the handrails until you become comfortable and familiar with the treadmill when first start the workout.
10. Treadmill is indoor-using equipment, not outdoor-using for avoiding damage. Keep the store-place clean and flat, drying. Prohibiting other purpose of using, only for workout.
11. Please purchase the power-line to the distributor or contact with us directly, for the power-line only equip to the treadmill.
12. If the treadmill suddenly increase in speed due to an electronics failure or the speed being inadvertently increased, the treadmill will come to a sudden stop when the pull pin is disengaged from the console.
13. Do not connect the line to the middle of cable; do not lengthen cable or change the cable plug; do not put any heavy thing on cable or put the cable near the heat source; forbid using socket with several holes, these may cause fire or people may be hurt by the power.
14. Cut off the power when the equipment is not used. When the power is cut off , do not pull the power line to keep the wire in good condition. Insert the plug to the socket with the safety ground circuit, for the power-line is professional equipment .You must contact with the professional people directly while the line is damaged.
15. This Treadmill only for home-using.
16. Safety area behind the treadmill: 1000*2000MM

Assembly Instructions

When you open the carton, and you will find the below parts in the carton

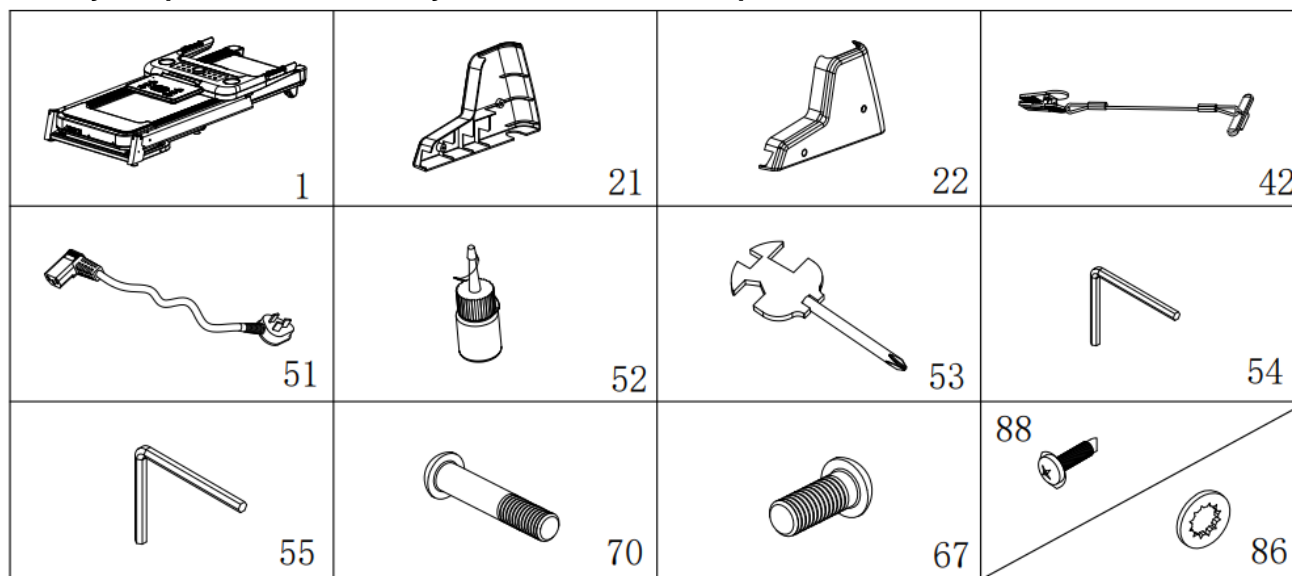

PART LIST:

NO	DES.	Specification	Nos.	NO	DES.	Specification	Nos.
1	Main frame		1	54	5#Allen wrench	5mm	1
21	Left base cover		1	55	6#Allen wrench	6mm	1
22	Right base cover		1	70	Bolt	M8*42	2
42	Safety key		1	67	Bolt	M8*16	4
53	Wrench with screw driver	S=13、14、15	1	88	Screw	ST4.2*19	4
52	Silicone oil		1	86	Lock washer	8	6
51	Power wire		1				

FIXING TOOLS:

5# Allen Wrench 5mm 1pc

6# Allen Wrench 6mm 1pc

Wrench with screw driver S=13、14、15 1pc

Notice: Do not get through power before complete assembly

STEP 1:

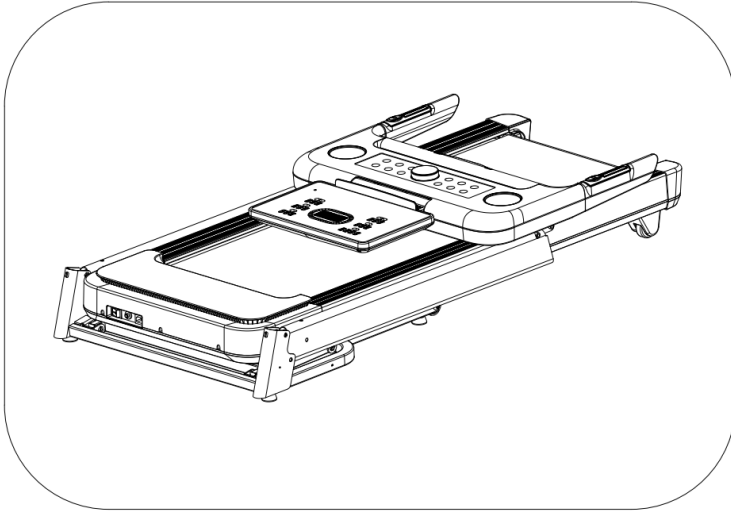

1. Open the carton, take out the above spare parts, put the Main Frame on the level ground.

STEP 2:

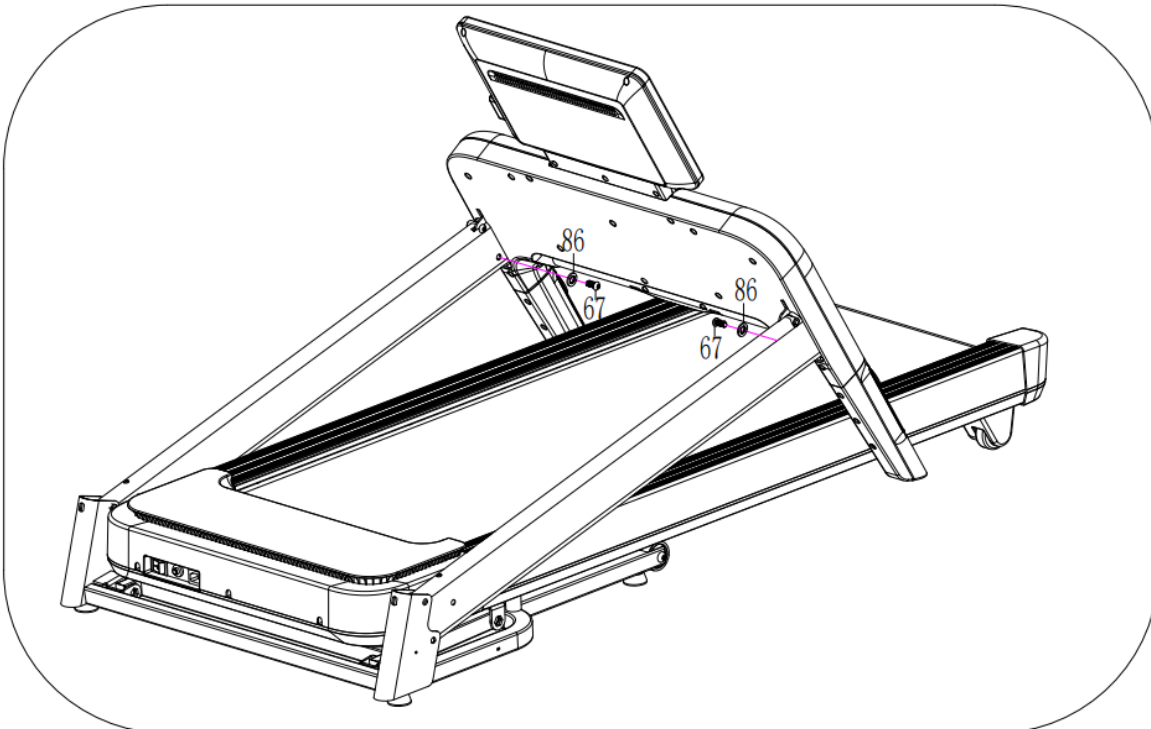

1. Support the computer bracket, and lock the computer on the upright tube with 5# Allen wrench(54), Bolt(67) and lock washer(86). refer to the picture left.

Left side the same as the right side.

Notice: Please hold the uprights with one hand, avoid to hurt anyone.

STEP 3:

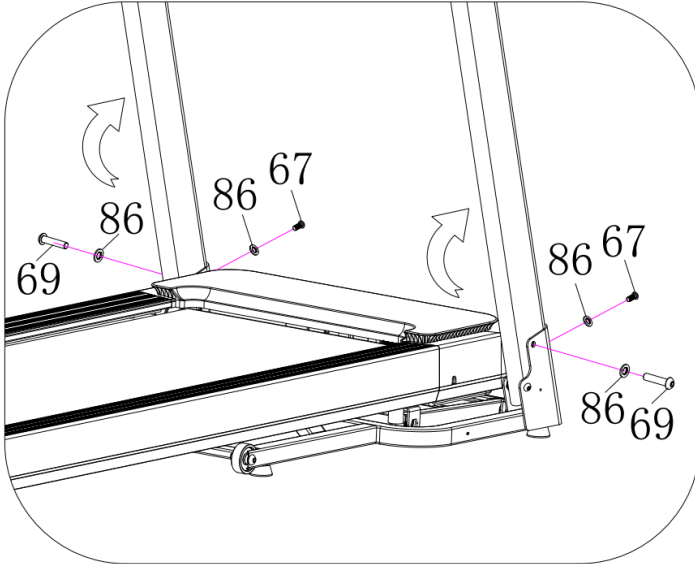

1. Use 5#Allen wrench (54), Bolt(69) and lock washer(86) to lock the right upright tube onto the base frame.
2. Use 5#Allen wrench (54), Bolt(67) and lock washer(86) to lock the right upright tube onto the base frame.
3. Left side is same as the right side.

Notice: Please hold the uprights with one hand, avoid to hurt anyone.

STEP 4:

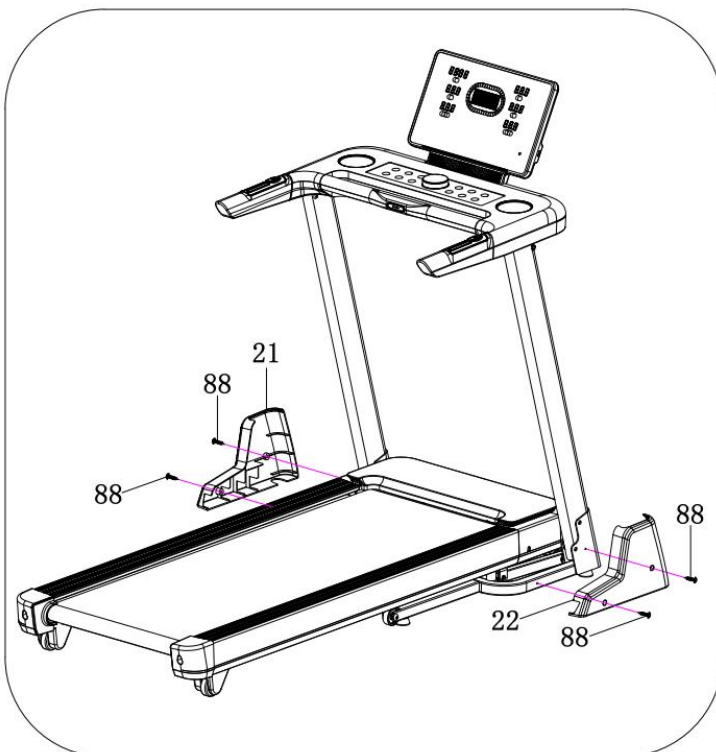

1. Use wrench with screw driver(53), bolt(88) to lock the right base cover (22) into the base frame.
2. Left side is same as the right side.

Note: The base cover needs to be fastened to the upright.

STEP 5:

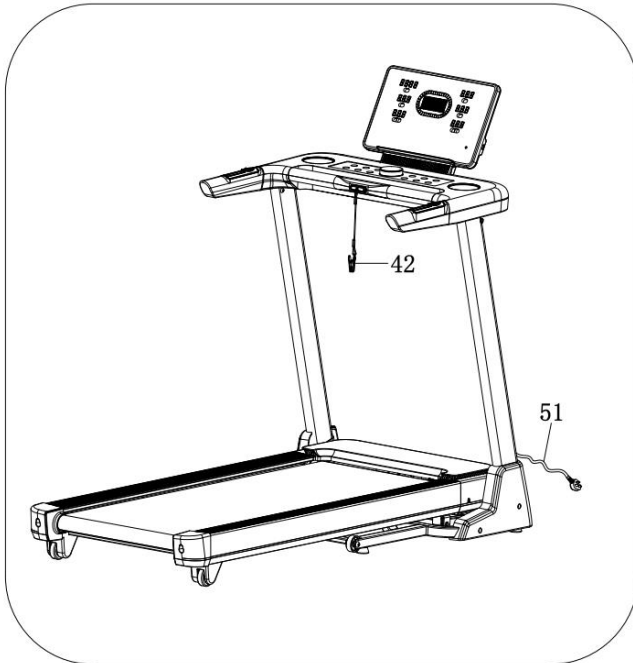

1. Put the safety key (42) on the computer.
2. Plug the power wire(51) on the socket on mainframe
(when you don't use treadmill, you can unplug the power wire.)

ATTENTION: Please confirm complete assembly as the require above and lock all the bolt. Do the following operation after checking everything is OK. Before you use the treadmill, please read the instruction carefully.

Folding Instruction

Pulling up:

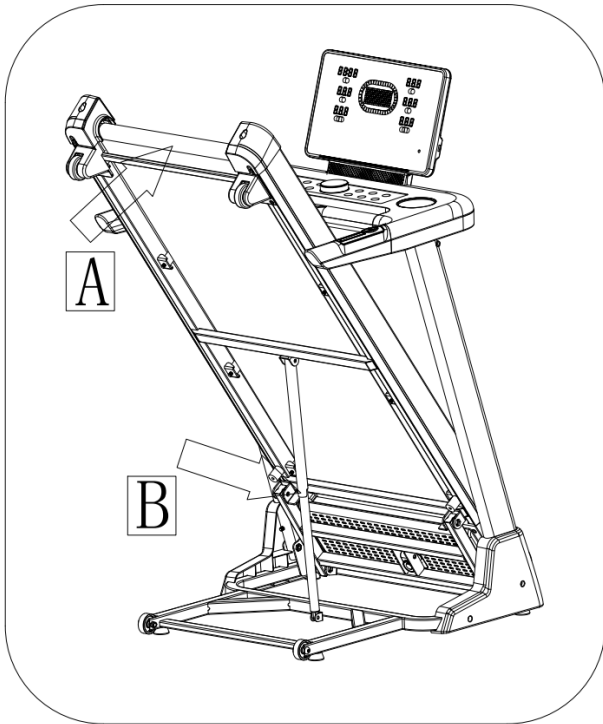

Pull up the base frame at position (A) till hearing the sound that the air pressure bar (B) is locked into the round tube.

Pulling down:

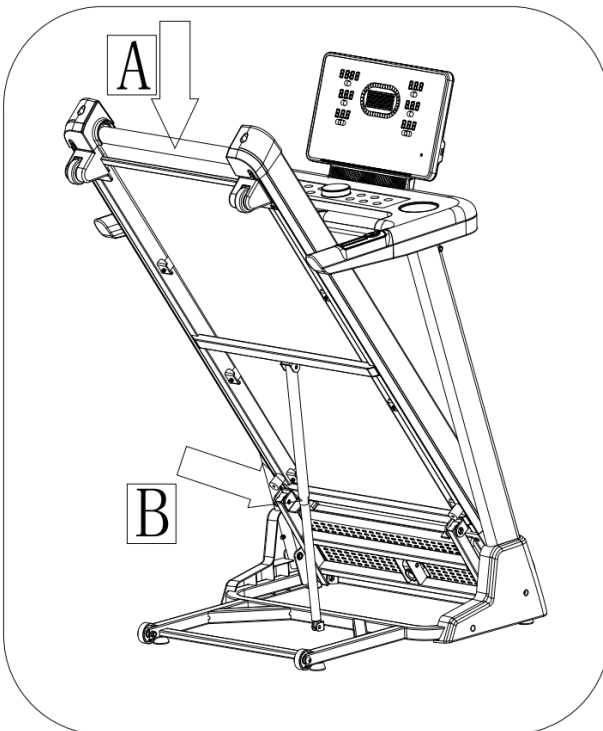

Support place A with hand , kick the place of air pressure bar, then the base frame will fall down automatically (**Please keep anybody and any pet away the machine when falling down**).

Technical Parameter

BUILT UP SIZE(mm)	1735*765*1348mm	POWER	As the rating label showing
FOLDABLE SIZE(mm)	985*765*1500mm	Maximum output power	As the rating label showing
RUNNING SURFACE SIZE(mm)	1400*480mm	SPEED RANGE	1.0-18KM/H
NET WEIGHT	68kg	MAX AFFORDABLE WEIGHT	120kg
LED WINDOW	Speed, Time, Incline, Distance, Calories, Pulse		

Grounding Methods

This product must be grounded. If it malfunction or breakdown, grounding provides a path of least resistance for electric current to reduce the risk of electric shock. This product is equipped with a cord having an equipment-grounding conductor and a grounding plug. The plug must be plugged into an appropriate outlet that is properly installed and grounded in accordance with all local codes and ordinances.

DANGER – Improper connection of the equipment-grounding conductor can result in a risk of electric shock. Check with a qualified electrician or serviceman if you are in doubt as to whether the product is properly grounded. Do not modify the plug provided with the product – if it will not fit the outlet, have a proper outlet installed by a qualified electrician. This product is for use on a nominal 220-240/100-120 volt circuit and has a grounding plug that looks like the plug illustrated in sketch A in following figure. Make that the product is connected to an outlet having the same configuration as the plug. No adapter should be used with this product. (The below picture is just for reference, the actual plug and jack is depends on import country)

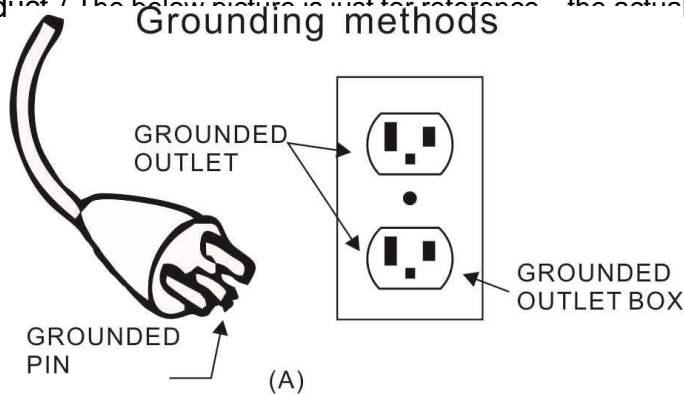

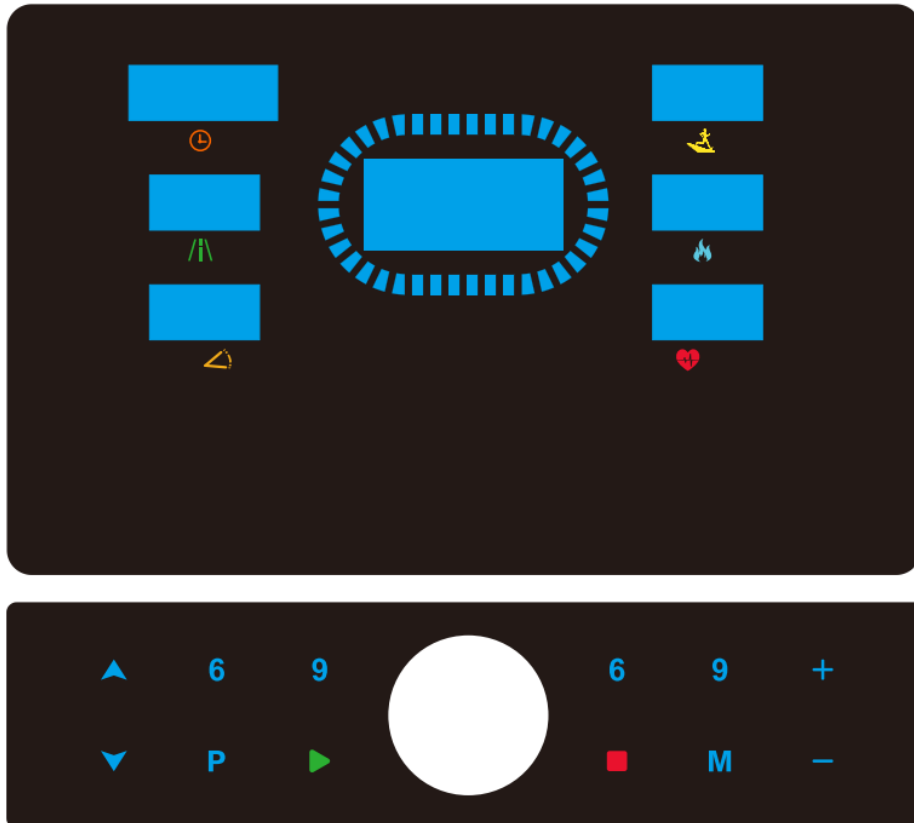

Operation Guide

1. DISPLAY WINDOW:



2. LED WINDOW DISPLAY DETAILS:

 **TIME:** Show running time, During the start-up process, a 3 second countdown is displayed: 3, 2, 1;

 **SPEED:** Show speed;

 **DIST:** Show distance;

 **CAL:** Show Calories;

 **INCLINE:** Show incline;

 **PULSE:** Show heart beat data;

Runway window: Shows the runway.

The middle window is showing running track and circle numbers (Displays the program segment when you select a program or run a program)

3. BUTTON FUNCTION

 **“PROG” button:** Press this button to choose program from manual

mode—P1---P15--U1--U3--FAT.

 **“MODE” button:** When machine in standby state, press this button to choose the mode: manual mode, time count down mode, distance count down mode, calories count down mode.

When machine in FAT mode, the choose sequence is “Sex” “Age” “Height” “Weight”.

 **“START” button:** Press this button to start the machine, the machine will run at the lowest speed or at the speed of default program after 3 seconds time count down.

 **“STOP” button:** Pause/Stop function. When the treadmill is running, Press this button once to slow down treadmill and stop. All data will remain. In this PAUSE state, If you press the "STOP" button once again, the machine will stop completely and all the data will reset. But in this PAUSE state, if you press START button, the treadmill will go on from the data of PAUSE state

“SPEED+/-”: Adjust the speed. Press the button to adjust the speed when running, or adjust the data when stop.

“SPEED (6,9) ”: Adjust the speed quickly.

“INCLINE ▲/▼”: Adjust the incline. Press the button to adjust the incline when running, or adjust the data when stop.

“INCLINE (6,9) ”: Adjust the incline quickly.

“SMART KNOB”: Including button, rotation,display functions

Middle Button: Short press for “START” and “PAUSE”, Long press for “STOP”. Short Press to start the machine, the machine will run at the lowest speed or at the speed of default program after 3 seconds time count down. When the treadmill is running, short press to slow down treadmill and stop. All data will remain. In this PAUSE state, if short press, the treadmill will go on from the data of PAUSE state.

In any state, If long press, the machine will stop completely and all the data will reset. Rotation:

Clockwise rotation for speed increases and counterclockwise rotation for speed decreases.

Display: display the data sync with window

Notice: When any button is pressed, it will be accompanied by a prompt tone. When the button is adjusted for parameter overrun, it will be accompanied by a long tone prompt. There is no beep when the button is pressed Invalid.

4. MAIN FUNCTION

Open the power switch, the screen window will light up, the machine will enter into standby state.

4.1. START-UP QUICKLY (MANUAL):

Put safety key, press ‘ START’ button, the treadmill will run at the lowest speed in 3 seconds, press **SPEED+/-** to adjust the speed. Press **INCLINE+/-** to adjust the incline. Press the ‘ STOP’ button or take out the safety key directly to stop the treadmill.

4.2. COUNT DOWN MODE:

Press the ‘ MODE’ button, you can choose time countdown mode, distance count down mode, calories

countdown mode, and the screen window will show the default data and glitter. At the same time, press **SPEED+/-** and **INCLINE+/-** to set the data. Press 'START' button, the machine will run at the lowest speed, you can press **SPEED+/-** to change the speed, press **INCLINE+/-** to change the incline. When it counts down to 0, the machine will stop smoothly. Certainly, you can press 'STOP' button or take out the safety key from the computer to stop the machine.

4.3. INNER INSTALL PROGRAM:

Press 'PROG' button to choose the inner install program from P1----P15. When set the program, the time window will show default data and glitter, press **SPEED+/-** or **INCLINE+/-** button to set the running time. Each program has been divided into 16 section, Each exercise time=the setting time/16. Press 'START', the machine will run at the first section speed and incline date. When the section is over, it will enter into next section automatically, the speed and incline will change as next section data. When finish one program, the machine will stop smoothly. During the running, you can change the speed and incline by the **SPEED+/-** and **INCLINE+/-** or **Left/right Handrail Button**. When the program enter next section will come back to the default date. And you can press 'STOP' or take out the safety key to stop the machine whenever.

4.4 USER DEFINED PROGRAM

There are three program U1, U2, U3 for user defined.

Press "PROGRAM" continuously under standby mode until window display U1-U3,press "MODE" to start setting first segment, setup speed and incline by pressing 'SPEED + -', 'SPEED (6 9)', "INCLINE + -", "NCLINE(6 9)", .press "MODE" finish first segment setting and enter second one, until finish all 20 segments. The data will be permanently saved until user reset next time.

The U1 is usually with default speed 1KM/H, incline 0. The U2 is usually with default speed 2KM/H, incline 0. The U3 is usually with default speed 3KM/H, incline 0.

· *At the end of the program mode the treadmill will flash with 15 beeps, after which all data will be cleared to 0 and come into standby status.*

5. HEART BEAT TEST

When holding the hand pulse by two hands, the pulse window will show your heart beat after 5 seconds. In order to get an accurate heartbeat value, please holding the hand pulse more than 30 seconds to test when the machine stop. The heart beat data is just for reference, can not be as the medical data.

6. BODY FAT TEST

When the treadmill standby, press 'PROGRAM' button till 'FAT' show in the window. 'FAT' is body fat test mode. Press 'MODE' to choose parameter 'SEX / AGE / HEIGHT / WEIGHT', Corresponding

window will show “-1-”, “-2-”、“-3-”“-4-”. When set each parameter, press SPEED+/--(INCLINE+/-) to adjust the data, and Corresponding window will show the data and press ‘MODE’ button to finish, the window will show“-5-” and“---” enter into ready to go condition. Hold the handle pulse with two hands, it will show your BMI data after 5 seconds.

6.1 Data display and set range

Parameter Type	default	Setting range	mark
SEX (-1-)	0 (MALE)	0—1	0= MALE 1= FEMALE
AGE (-2-)	25	10—99	
HEIGHT (-3-)	170 CM	100—240 CM	
WEIGHT (-4-)	70KG	20—160KG	

6.2 BMI reference

(BMI)	
<19	Under weight
19--26	Normal weight
26--30	Over weigh
>30	Obesity

7. SLEEP FUNCTION

No operation when the system stops, 2 minutes later, the system returns to the standby state and the backlight is off. Stopped more than 10 minutes, the system turns off all displays and enters a sleep mode. Press any key to wake up.

8. SAFETY KEY FUNCTION

Whenever pull out the safety key, the treadmill will stop quickly, all data turn to zero, All the windows display “---” . All normal operation must under safety key locked condition.

9. RUNNING DATA DISPLAY AND SETTING RANGE

	SHOW RANGE	DEFAULT MODE	DEFAULT PROGRAM	SET RANGE
SPEED(KM/H)	1.0-18.0KM	-----	-----	1.0-18.0KM
INCLINE(%)	0-15%			0-15%
TIME	0:00—99:59	30:00	30:00	5:00---99:00
DISTANCE	0.00KM—99.9KM	1.00KM	-----	0.50KM—99.9KM
CALORIES	0Kcl—999Kcl	50Kcl	-----	10Kcl—990Kcl

10. DATE TABLE:

PROG	TIME	Setting time/16= interval running time															
		1	2	3	4	5	6	7	8	9	10	11	12	13	14	15	16
P01	SPEED	2	3	3	4	4	5	5	3	4	5	4	4	3	3	5	3
	INCLINE	1	1	2	2	3	3	2	2	1	2	2	1	3	2	2	2
P02	SPEED	2	4	4	5	6	6	6	4	5	6	4	4	2	5	4	2
	INCLINE	1	2	2	2	3	2	2	2	2	2	3	3	4	3	2	2
P03	SPEED	2	4	4	6	7	7	7	4	7	7	4	4	4	5	3	2
	INCLINE	2	3	3	2	3	3	2	2	2	2	4	4	6	3	2	2
P04	SPEED	3	5	5	6	5	7	7	8	8	5	9	5	6	4	4	3
	INCLINE	2	3	3	2	3	3	2	2	2	2	4	4	6	3	2	2
P05	SPEED	2	4	4	5	7	5	6	7	8	8	5	4	6	5	4	2
	INCLINE	3	3	3	4	5	5	4	4	4	4	5	5	3	2	2	2
P06	SPEED	2	4	4	4	8	8	6	7	8	8	6	4	5	4	3	2
	INCLINE	3	5	5	5	4	3	3	3	3	4	4	4	3	4	3	2
P07	SPEED	2	3	3	3	3	4	5	3	4	5	3	3	6	5	3	3
	INCLINE	4	4	4	4	6	6	6	7	7	8	8	9	6	5	4	4
P08	SPEED	2	3	3	6	4	6	7	4	6	7	4	4	3	4	4	2
	INCLINE	4	5	5	5	6	7	8	9	9	9	10	10	12	8	6	3
P09	SPEED	2	4	4	7	7	8	4	8	9	9	4	4	6	3	3	2
	INCLINE	5	5	5	6	4	4	6	6	5	5	8	8	9	7	4	2
P10	SPEED	2	4	5	6	4	6	8	8	6	6	5	4	4	4	3	3
	INCLINE	5	6	6	6	8	8	4	4	4	5	5	8	10	8	6	3
P11	SPEED	2	5	8	10	10	10	7	7	10	10	5	5	5	5	4	3
	INCLINE	4	5	3	2	2	2	2	2	2	4	5	6	5	5	2	0
P12	SPEED	3	4	9	9	5	8	5	9	7	5	5	7	5	7	6	3
	INCLINE	1	2	3	2	5	0	0	2	3	5	7	3	6	5	3	3
P13	SPEED	3	6	7	5	7	5	5	7	9	5	8	5	9	9	4	3
	INCLINE	3	3	5	6	3	7	5	3	2	0	0	5	2	3	2	1
P14	SPEED	2	2	4	5	4	3	2	1	2	3	4	5	4	3	2	1
	INCLINE	4	4	4	4	6	6	6	7	7	8	8	9	6	5	4	4
P15	SPEED	2	4	6	8	4	4	2	2	2	4	6	8	4	4	2	2
	INCLINE	3	3	3	4	5	5	4	4	4	4	5	5	3	2	2	2

11. Bluetooth speaker function

Open the Bluetooth of your phone or IPAD searching the Bluetooth, after successfully connect to it. The music you play on Phone or IPAD will sing from treadmill speaker.

BLUETOOTH APP

1. ZWIFT



Search, download, and install ZWIFT over the App Store.

- [1]** Enter ZWIFT to register an account;
- [2]** Login account to select the paired riding or running equipment;
- [3]** Pair device successfully, tap OK to start sport;

[4] For riding equipment, start riding directly. For running equipment, need to press the start button to start running.

2. Kinomap

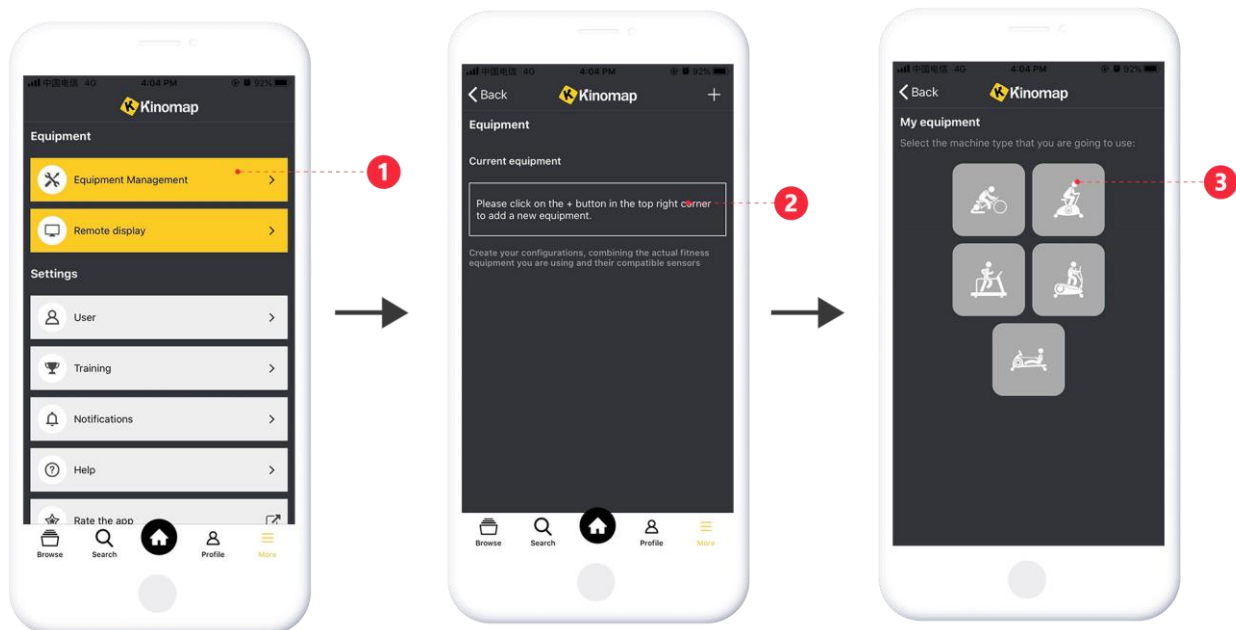

Search, download, and install Kinomap over the App Store.

- [1]** Enter Kinomap to select [More] page;
- [2]** Select to add more fitness equipment;
- [3]** Select the desired device type;

Exercise Instructions

1. Tap the matching devices

Warm up stage:

If you are over 35 years old, or not very healthy, also it's your first time exercise, please consult with your doctor or professional person.

Before you use the motorized treadmill, please learn how to control the machine, know well how to start, stop, adjust the speed and so on, don't stand on the machine at this time. After that, you can use the machine. Stand on anti-slip pad both sides and handle the handle bar with your both hands. Keep the machine at the low speed about 1.6~3.2 km/h, then test the running machine by one foot, after get used to the speed, then you can run on the machine and you can add the speed between 3 and 5 km/h. Keep the speed about 10 minutes, then stop the machine.

Exercise stage:

Learn how to adjust the speed and incline before using. Walk about 1 km at stable velocity and write down the time, it will take you about 15-25 minutes. If walk at 4.8 km/h, it will take you about 12 minutes in 1 km. If you feel comfortable at the stable velocity, you can add the speed and incline, after 30 minutes, you can have good exercise. At this stage, you can not add the speed or incline too much at one time, it can keep you feel comfortable.

Exercise intensity:

Warm up at the speed 4.8 km/h in 2 minutes, then add the speed to 5.3 km/h and keep walking in 2 minutes, then add to 5.8km/h and walk in 2 minutes. After that, add up 0.3 km/h in each 2 minutes, until rapid breath but not feel comfortable

Calorie burning---the best effective way

Warm-up for 5mints by the velocity:4-4.8KM/H, then slowly increase the speed by 0.3KM/H/2Mints ,until up to the stable speed which you feel is comfortable for 45Mints.For improving the intensity of movement, you can maintain the speed during 1H of TV program, then increase the speed by 0.3KM/H each Advertisement interval time, after that return to the original speed . You can acquaint the best efficiency of workout for calorie burning during the advertisement time and subsequent heart frequency increasing time. Finally , you should slow down the speed step by step for 4Mints.

Exercise frequency:

The cycle time: 3-5times/Week, 15-60mints/Times.Make up the schedule of workout scientific, not only for your hobby.

You can control the running intensity through adjusting the velocity and incline of treadmill. We suggest that you don't set the incline at first; improve the incline is the effective way to strengthen the exercise's intensity.

Consult with your physician or health professional before starting your workout. The professional people can help you make up the suitable exercise time-chart according to your age and health condition, determine the velocity of movement, the intensity of exercise. Please stop at once, If you feel chest tightness, chest pain, irregular heart beat, breath difficulty, dizziness or other discomfort during exercise.

You should consult with your physician or health professional as keep going.

You can choose the normal walking speed or the jogging speed ,if you always take workout with treadmill.

If you don't have enough experiences or confirm the testing velocity ,you can follow the instruction :

- Speed 1-3.0KM/H not well physical
- Speed 3.0-4.5KM/H less movement and workout
- Speed 4.5-6.0KM/H normal walking
- Speed 6.0-7.5KM/H Fast walking
- Speed 7.5-9.0KM/H Jogging
- Speed 9.0-12.0KM/H intermediate speed walking
- Speed 12.0-14.5M/H well experiences of running
- Speed 14.5-16.0KM/H excellent runner

Attention: The velocity of movement $\leq 6\text{KM/H}$, **the normal walking**; The velocity of movement $\geq 8.0\text{KM/H}$,**the good runner**.

WARM UP INSTRUCTION

Before exercise, it is better to do stretching exercises .

Warm muscles stretch more easily, spend the first of 5 ~ 10 minutes to warm up. Then in accordance with the following methods to stop and do stretching exercises - do five times, each leg every time 10 seconds or more time to do it again after the end of the exercise.

1. Down the stretch: knees slightly curved, the body bent forward slowly, so that the back and shoulders relaxed, hands try to touch your toes. Maintain 10 to 15 seconds, then relax. Repeat three times to do (see Figure 1).

2. Hamstring stretch: sitting on the clean seat, put one leg straight. Inward close to the other leg to make it close to the inside leg straight. hand try to touch the toes. Maintain 10 to 15 seconds, then relax. Repeat for each leg do three times (see Figure 2).

3. Legs and feet tendon stretch: two on the Rotary wall or tree stand, one foot in the post. Keep legs straight and heel to tilt the direction of the wall or tree. Maintain 10 to 15 seconds, then relax. Repeat for each leg do three times (see Figure 3).

4. XXXXXXXXXX 17 ch: the left hand wall or table to master balance, and then stretched his right hand back to seize the right foot to the buttocks with slowly pull until you feel the

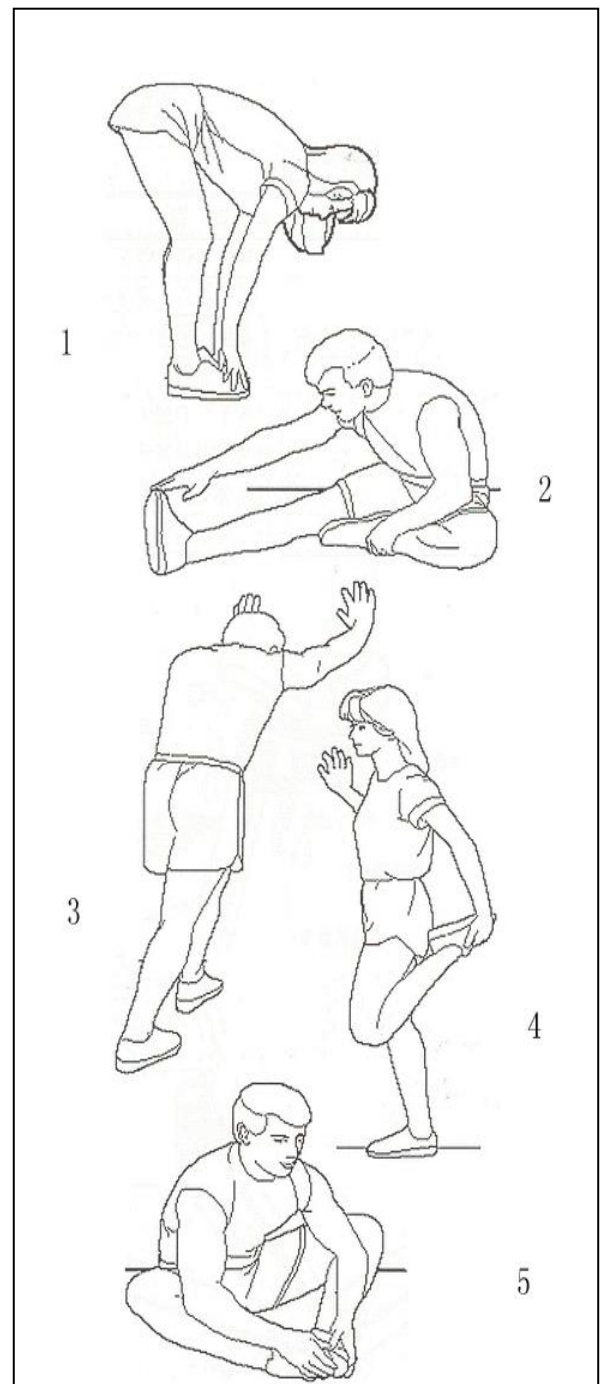

RUNNING BELT ADJUSTMENT

Warning: ALWAYS UNPLUG THE TREADMILL FROM THE ELECTRICAL OUTLET BEFORE CLEANING OR SERVICING THE UNIT.

Clean: General cleaning the unit will greatly prolong the treadmill.

Keep treadmill clean regularly. Be sure to clean the exposed part of the deck on either side of the walking belt and also the side rails. This reduces the build up of foreign material underneath the walking belt by wearing the clean running shoes.

Warning: Always unplug the treadmill from the electrical outlet before removing the motor cover. At least once a year remove the motor cover and vacuum under the motor cover.

RUNNING BELT AND DECK LUBRICATION

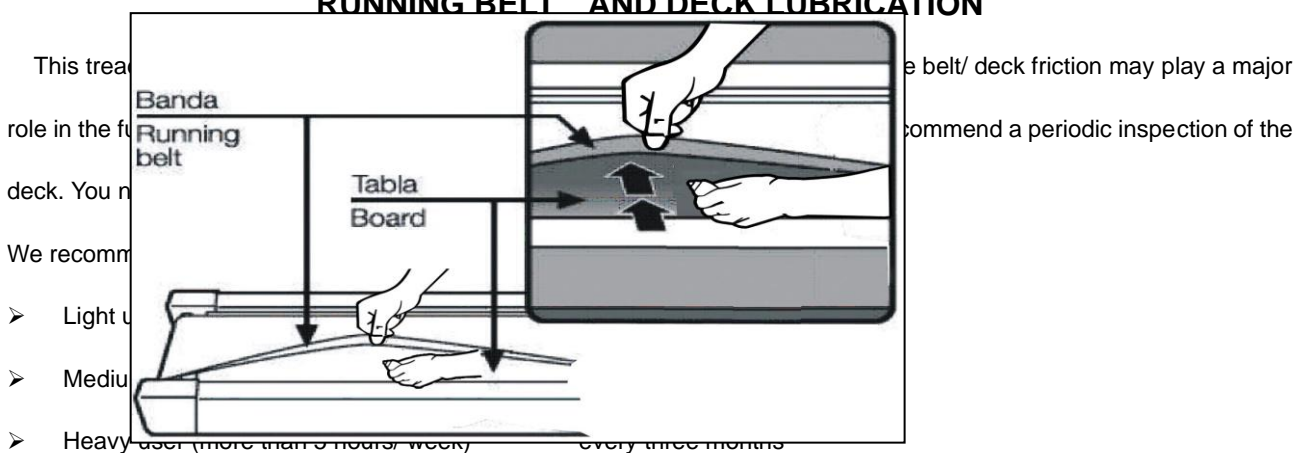

We recommend that you buy the lubrication from our distributor or directly to our company.

Attention: Any repair need professional technician.

CENTER THE RUNNING BELT

1, We suggest that you should cut off the power for 10Mints after keep running 2HS ,so that it's good for maintain the treadmill.

2,For avoiding the slipping during running , the belt not too loose; for avoiding the more abrasion between the roller and belt and maintain the machine's good running ,the belt not too tight. You can adjust the distance between plates and belt , the belt be away from the plates about 50-75mm on both sides ,if the best not too tight nor loose.

- Place treadmill on a level surface. Run Treadmill at approximately 6-8KM/H, checking the running condition.

If the belt has drifted to the right, pull out of the save clock and switch, turn the right adjusting bolt 1/4 turn clockwise, then start running until centering the belt. PIC A

If the belt has drifted to the left ,pull out of the safety clock and switch, turn the left adjusting bolt 1/4 turn clockwise ,then start running until centering the belt .PIC B

Timely adjust the tightness of the belt ,for the looseness after a period of time running. Pull out of the safety clock and switch , turn the left and right adjusting bolt 1/4 turn clockwise ,then re-start running, confirm the belt-tightness until the belt be right tightness. PIC C

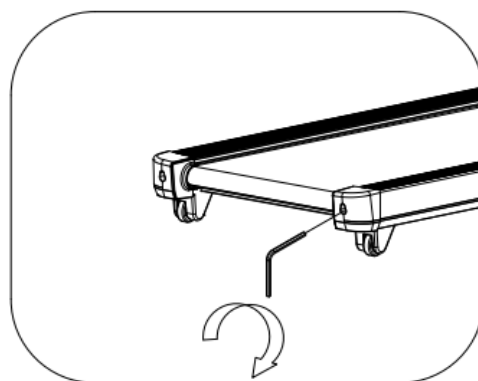

A

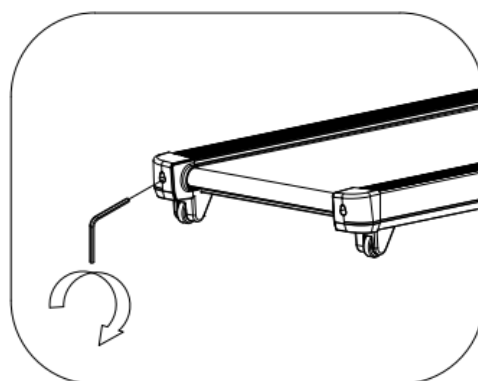

B

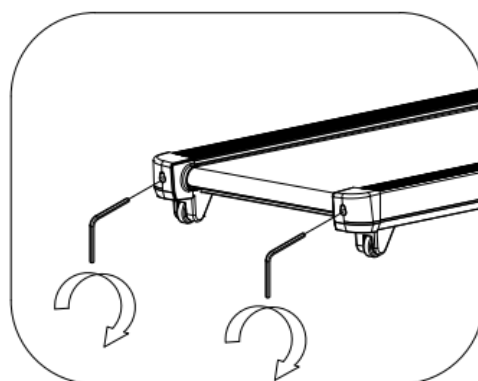

C

Exploded Parts Diagram

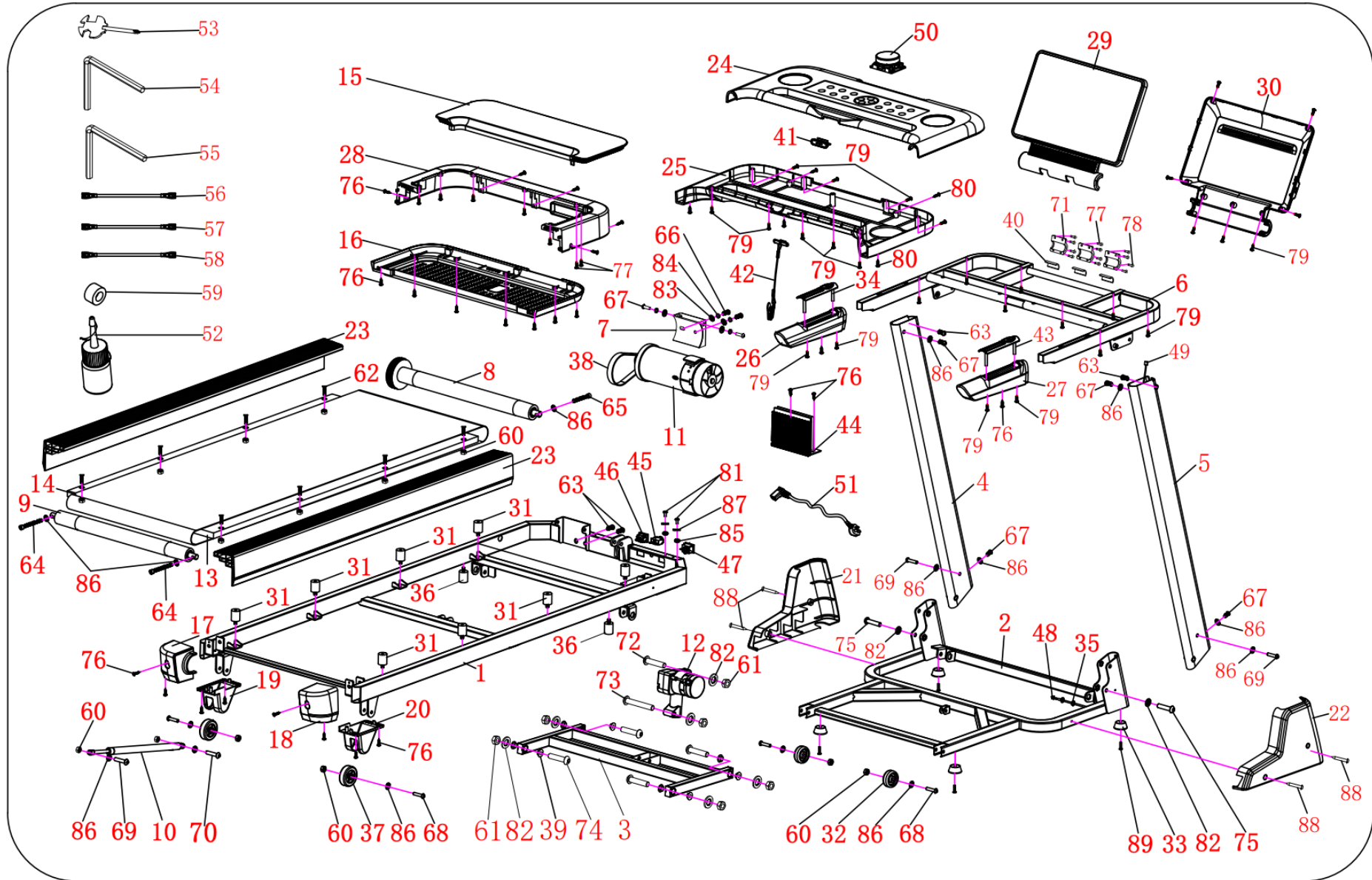

Part list

NO.	DESCRIPTION	SPECS.	QTY	NO.	DESCRIPTION	SPECS.	QTY
1	Main frame		1	46	Switch		1
2	Base frame		1	47	Power wire socket		1
3	Incline bracket		1	48	Computer bottom wire		1
4	Left upright bracket		1	49	Computer top wire		1
5	Right upright bracket		1	50	Smart Knob		1
6	Computer bracket		1	51	Power wire		1
7	Motor fix seat		2	52	Silicone oil		1
8	Front roller		1	53	Wrench with screw driver		1
9	Rear roller		1	54	5# Allen wrench		1
10	Cylinder		1	55	6# Allen wrench		1
11	DC motor		1	56	AC single wire		1
12	Incline motor		1	57	Blue single wire		1
13	Running board		1	58	Brown single wire		1
14	Running belt		1	59	Magnetic ring		1
15	Motor top cover		1	60	Lock nut	M8	14
16	Motor bottom cover		1	61	Lock nut	M10	6
17	Left back end cap		1	62	Bolt	M8*25	8
18	Right back end cap		1	63	Bolt	M8*25	4
19	Left wheel cover		1	64	Bolt	M8*65	2
20	Right wheel cover		1	65	Bolt	M8*45	1
21	Left base cover		1	66	Bolt	M8*14	2
22	Right base cover		1	67	Bolt	M8*16	6
23	Side rail		2	68	Bolt	M8*40	4
24	Computer top cover		1	69	Bolt	M8*42	3
25	Computer bottom cover		1	70	Bolt	M8*25	1
26	Left hand bar		1	71	Tile pressure plate		3
27	Right hand bar		1	72	Bolt	M10*42	1
28	Motor front cover		1	73	Bolt	M10*55	1
29	LED display panel		1	74	Bolt	M10*45	4
30	Panel bottom cover		1	75	Bolt	M10*45	2
31	Cushion		8	76	Screw	ST4.2*15	24
32	Moving wheel		2	77	Screw	ST4.2*15	13
33	Foot pad		4	78	Screw	ST4.2*20	6
34	Hand Pulse with incline + - button		1	79	Screw	ST4.2*13	28
35	Ring wire protector B		1	80	Screw	ST4.2*19	5
36	Buffer nut post		2	81	Bolt	M5*8	2
37	Wheel		2	82	Lock washer	10	8
38	Motor belt		1	83	Lock washer C level	8	4
39	Spacer sleeve		8	84	Spring washer	8	4
40	Tile		3	85	Lock washer	5	2
41	Safety key seat		1	86	Lock washer	8	15
42	Safety key		1	87	Spring washer	5	2
43	Hand Pulse with speed + - button		1	88	Screw	ST4.2*19	4
44	Control board		1	89	Screw	ST4.2*25	4
45	Overload protector		1				

TROUBLE SHOOTING GUIDE

CODE	REASON	SOLUTION
E01	1.message wire is broken or not connected well	<ol style="list-style-type: none"> 1. Check if the computer and bottom control board wire connect well; 2. Check if IC on bottom control board is loosen, reset the IC
E02	1. Burst clash	<ol style="list-style-type: none"> 1. Check if the power voltage is 50% lower than the normal voltage, please use the normal voltage to test; 2. check if the control board is burnt with irregular smell, replace a control board; 3. Check if the motor wire is well connected, reconnect it.
E03	no sensor signal	<ol style="list-style-type: none"> 1. Check if the signal light on control board is light on, if the signal light is burnt out, change a signal light. 2. Check if the plug of sensor is well connected 3. Check if the magnetic sensor is broken or well connected, reconnect it or replace a magnetic sensor.
E05	Current overload protecting	<ol style="list-style-type: none"> 1. Over rated loaded or the motor is stuck, cause excessive current, machine will start self-protecting system. Adjust the machine and restart; 2. Check if the motor has noise from motor or if the motor / bottom control board were burnt out, if burnt out, change motor and bottom control; 3. Check if the power voltage is wrong, use right voltage to test again.
Show "----"	<ol style="list-style-type: none"> 1. The safety key is not at the appointed site 2. The safety key is not connected well or broken 	<ol style="list-style-type: none"> 1. Check if the safety key is at the appointed site. 2. Check if the safety key sensor board is connected well 3. Replace the safety key sensor board inside computer
<p>If the motor doesn't rotate after press "START" button. The wire that control the motor might have something wrong. Such as the protective tube on control board is damaged or fall off,. Or the motor wire isn't connected well.Or the IGBT on control board is burnt out Check if the motor wire is connected well and re-connect well.Check if the protective tube is OK, re-set it or change one. Use multimeter to test if the IGBT is burnt out,and change an IGBT or control board.</p>		
E07/E08	EEPROM damaged	Change a control board

