



COSCO[®]
SPORTS | FITNESS

COMMERCIAL
CATALOGUE-2025

COSCO (India) Limited

ProductRange:

Sporting Goods, Fitness Equipments

COSCO is a leading Sports & Fitness Products Company in India since 1980 and Exports to many Countries Worldwide. COSCO represents many top Brands like : TRETORN (Sweden), STIGA (Sweden), Newgy (USA), JKEXER (Taiwan), Fitlux (Taiwan), JK Fitness (Taiwan) ADIDAS, REEBOK, IMPULSE (U.K), FORCE USA for Indian Market.

Head Office : 2/8 Roop Nagar, Delhi-110007 (INDIA)

Work Area : Factory Area-200,000+ sq. ft. in Gurugram, Haryana

Work Force : Team of Management, Sales, Service and workers of 700+

Marketing & Service : The Company has a full-fledged Marketing Division supported by Sufficient Staff and Distribution Network of around 700 Dealers covering all the States in India. We have efficient After Sales Service and provide good back up Facilities to our Customers.

R & D and Quality Control :

Committed to Quality - Its our constant endeavor to provide & delight consumers with New and Innovative Products having better Design, Engineering and Aesthetic Appeal. All products are Tested to International Standard and are Manufactured/ Sourced to make the best available.

FOLLOW US ON SOCIAL MEDIA

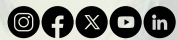



COronation Sporting COmpany

CONTENTS

COMMERCIAL CARDIO

06-07	CURVED TREADMILL
08-15	MOTORISED TREADMILL
16-21	MOTORISED TREADMILL- SEMI
22-27	ELLIPTICAL
28-32	ELLIPTICAL-SEMI
33-34	UPRIGHT
35-37	UPRIGHT-SEMI
38-40	RECUMBENT
41	RECUMBENT-SEMI
42-47	GROUP CYCLING
48-49	STAIR CLIMBER
50	AIR BIKE
51-52	ROWER
53	ROWER-SEMI

STRENGTH EQUIPMENTS

54-57	MAGNUM - SINGLE STATION
58-61	MAGNUM - DUAL STATION
62-64	NITRO - SINGLE STATION
65-67	NITRO - DUAL STATION
68-72	ELITE - SINGLE STATION
73-75	ELITE - DUAL STATION
76-81	STEALTH - SPECIAL PLATE LOADED
82-86	CANON II - PLATE LOADED
87	CANON I - PLATE LOADED
88-91	MULTI STATION GYM
92-94	CABLE CROSSOVER
95-96	FUNCTIONAL TRAINER
97-98	POWER RACK
99-104	SPECIAL MACHINES
105	CROSSFIT
106-113	NITRO MAGNUM - NON WEIGHT STATION
114-120	CTB -NON WEIGHT STATION
121-126	ELITE -NON WEIGHT STATION
127-130	CFE -WEIGHT STATIONS
131-133	CIE -NON WEIGHT STATION
134-138	CS -NON WEIGHT STATION
139	ADJUSTABLE DUMBBELL

PRODUCT DISPLAY AT GURUGRAM OFFICE





CRUSADE-II

Product Code: 42100

Curved Running Treadmill, No Motor, LCD Screen. Longer Service Life as there are No Motorised Parts. Less Friction and No Heat Generation Makes it Safer than Traditional One. Run More Naturally and Burn More Calories. Propelling Technique required to Drive the Running Belt, more Muscle Groups and Expend more Energy.

- Motor : No Motor (Less Friction and No Heat Generation Makes it Safer than Traditional One)
- Display : 40x125mm LCD Screen
- Running Belt : Propelling Technique to Drive the Running Belt
- Running Area : 1600 x 480 mm
- Max. User Weight : 200 Kgs.
- Net Weight : 230 Kgs.
- Assembly (LxWxH) : 2000 x 900 x 1550mm
- Foldable : No
- Noise Level : Noise Degree Below 80dB
- Other Features : Longer Service Life as there are no Motorised Parts. Run More Naturally and Burn More Calories. More Muscle Groups and Expend More Energy. Aluminium Plate insert in belt for extra longer life.



No Motor



CRUSADE 3.0

Product Code: 42153

Curved Running Treadmill, No Motor, LCD Screen. Longer Service Life as there are No Motorised Parts. Less Friction and No Heat Generation Makes it Safer than Traditional One. Run More Naturally and Burn More Calories. Propelling Technique required to Drive the Running Belt, more Muscle Groups and Expend more Energy.

- Motor : No Motor (Less Friction and No Heat Generation Makes it Safer than Traditional One)
- Display : 40x125mm LCD Screen
- Running Belt : Propelling Technique to Drive the Running Belt
- Running Area : 1700 x 440 mm
- Max. User Weight : 200 Kgs.
- Net Weight : 165 Kgs.
- Assembly (LxWxH) : 1975 x 855 x 1580mm
- Foldable : No
- Noise Level : Noise Degree Below 80dB
- Other Features : Longer Service Life as there are no Motorised Parts. Run More Naturally and Burn More Calories. More Muscle Groups and Expend More Energy. Aluminium Plate insert in belt for extra longer life.



No Motor

MOTORIZED TREADMILL



AC Motor



Emergency Stop



Motor Incline



Touch Screen



USB Port



Auto Lubrication

AC-18T (Touchscreen)

Product Code: 42152

A new design Treadmill for the Elite Runner. AC-18T AC Duty Treadmill suitable for Commercial Environment. Equipped with Auto Lubrication System, ensures smooth running of the treadmill over the years. Shock Absorbed Running Deck absorbs the shock of your running impact, which can translate to less stress on your joints than running over hard surfaces.

- Motor : 5HP (10HP Peak) AC Continuous Duty
- Speed Range : 1~22km/h
- Incline : Push Button Incline 0~16%
- Running Belt : 23 x 65" (580 x 1640mm)
- Display : 22.5" HD LED Touchscreen
- Max. User Weight : 200 Kgs.
- Net Weight : 200 Kgs.
- Assembly (LxWxH) : 2200 x 920 x 1540mm
- Foldable : No
- Emergency Stop : Yes
- Other Features : Auto Lubrication System, Shock Absorbed Running Deck

ELECTRONICS

- Functions : Mp3 and USB, Mobile/Water Bottle Holder, 18 Preset Programs, 4 User + 2 HRC
- Displays : Time, Speed, Distance, Pulse, Calories, Body Fat



Wireless Phone Charger

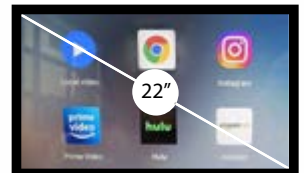

**MEGA
SCREEN DISPLAY**



AC Motor



Emergency stop



Motor Incline



USB Port



Auto Lubrication

AC-18

Product Code: 42151

A new design Treadmill for the Elite Runner. AC-18 AC Duty Treadmill suitable for Commercial Environment. Equipped with Auto Lubrication System, ensures smooth running of the treadmill over the years. Shock Absorbed Running Deck absorbs the shock of your running impact, which can translate to less stress on your joints than running over hard surfaces.

- Motor : 5HP (10HP Peak) AC Continuous Duty
- Speed Range : 1~22km/h
- Incline : Push Button Incline 0~16%
- Running Belt : 23 x 65" (580 x 1640mm)
- Display : 7 LED Windows
- Max. User Weight : 200 Kgs.
- Net Weight : 200 Kgs.
- Assembly (LxWxH) : 2200 x 920 x 1540mm
- Foldable : No
- Emergency Stop : Yes
- Other Features : **Auto Lubrication System, Shock Absorbed Running Deck**

ELECTRONICS

- Functions : Mp3 and USB, Mobile/Water Bottle Holder, 18 Preset Programs, 4 User + 2 HRC
- Displays : Time, Speed, Distance, Pulse, Calories, Body Fat



MOTORIZED TREADMILL



AC Motor



Emergency stop



Motor Incline



Touch Screen



USB Port

C-5ST (Touchscreen)

Product Code: 42150

A Robust commercial grade treadmill with 21.5" touch screen. Wide colourfull display screen with ease of choosing between various options and exercise routines. Long running length gives comfort for tall runners.

- Motor : 4HP (8HP Peak) AC Continuous Duty
 - Speed Range : 1~20km/h
 - Incline : Motor Incline 0~20%
 - Running Belt : 23 x 66" (580 x 1670mm)
 - Display : 21.5" Touchscreen Display
 - Max. User Weight : 200 Kgs.
 - Net Weight : 280 Kgs.
 - Assembly (LxWxH) : 2330 x 940 x 1700mm
 - Foldable : No
 - Emergency Stop : Yes
 - Other Features : Mp3 and USB ,High Grade German Make Running Belt, Backlit LED offers Reduced Energy Consumption, Better Contrast and Brightness, Greater Colour Range
- **ELECTRONICS**
- Displays : Time, Speed, Distance, Pulse, Calories, Incline, Heart Rate



**LARGE
SCREEN DISPLAY**



AC Motor



Emergency stop



Motor Incline



USB Port

CX-9

Product Code: 42105

New age Design, 3.0 HP AC Duty Machine with LCD Window Displays : Speed, Distance, Time, Calories, Program, Level, Pulse, Heart Rate, Body Fat. Light Weight Aluminium Alloy Side Posts and Side Rails.

- Motor : 3HP (6HP Peak) AC Continuous Duty
- Speed Range : 1.0~25 Kph.
- Incline : Auto Incline 0~18%
- Running Belt : 24 x 65" (600 x 1650mm)
- Display : 7" LCD Blue Backlit
- Max. User Weight : 200 Kgs.
- Net Weight : 225 Kgs.
- Assembly (LxWxH) : 2255 x 1000 x 1500mm
- Foldable : No
- Emergency Stop : Yes

ELECTRONICS

- Functions : USB, Emergency Stop and Bottle Holders.
- Displays : Time, Speed, Distance, Pulse, Calories, Heart Rate, Incline



MOTORISED TREADMILL



AC
Motor



Emergency
stop



Motor
Incline



USB
Port

C-5S

Product Code: 42145

A Robust commercial grade treadmill with LED display screen. Very functional and simple to use machine. Best in class German made running belt. Long running length gives comfort for tall runners.

- Motor : 4HP (8HP Peak) AC Continuous Duty
- Speed Range : 1~20km/h
- Incline : Motor Incline 0~20%
- Running Belt : 23 x 66" (580 x 1670mm)
- Display : LED Screen Display
- Max. User Weight : 200 Kgs.
- Net Weight : 280 Kgs.
- Assembly (LxWxH) : 2330 x 940 x 1700mm
- Foldable : No
- Emergency Stop : Yes
- Other Features : Mp3 and USB, High Grade German Make Running Belt, Backlit LED offers Reduced Energy Consumption, Better Contrast and Brightness

ELECTRONICS

- Displays : Time, Speed, Distance, Pulse, Calories, Incline, Heart Rate





AC Motor



Emergency stop



Motor Incline



USB Port

AC 100

Product Code: 42167

A Robust commercial grade treadmill with LED display screen. Very functional and simple to use machine. Best in class German made running belt. Long running length gives comfort for tall runners.

- Motor : 4HP (8HP Peak) AC Continuous Duty
- Speed Range : 1~25km/h
- Incline : Motor Incline 0~20%
- Running Belt : 24 x 65" (600 x 1650mm)
- Belt Thickness : 2.8mm
- Display : 4 LED Window Display
- Max. User Weight : 200 Kgs.
- Net Weight : 170 Kgs.
- Assembly (LxWxH) : 2380 x 1040 x 1615mm
- Emergency Stop : Yes
- Other Features : Wireless charging, FITSHOW app

ELECTRONICS

- Displays : Time, Speed, Distance, Pulse, Calories, Heart Rate



Wireless Phone Charger



AC Motor



Emergency stop



Motor Incline



USB Port



Fan

X-8200A

Product Code: 50004

New age Treadmill with RhymeBus Inverter- Taiwan and Reversible Running Board ensures smooth running of the treadmill over the years.

- Motor : 3HP AC (6HP Peak) Continuous duty
- Speed Range : 1~20km/h
- Incline : Auto Incline 0~15%
- Running Belt : 20 x 60" (520 x 1500mm)
- Belt Thickness : 2.2mm
- Display : 7 LED Window
- Max. User Weight : 200 Kgs.
- Net Weight : 196 Kgs.
- Assembly (LxWxH) : 2180 x 930 x 1420mm
- Emergency Stop : Yes
- Special Features : RhymeBus Inverter - Taiwan, Reversible Running Board

ELECTRONICS

- Functions : Mp3 and USB, Displays : Time, Speed, Distance, Pulse, Calories, Heart Rate, Mobile/ Water Bottle Holder, 18 Preset Programs, 4 User + 2 HRC



Inverter- Taiwan



AC Motor



Emergency stop



Motor Incline

HULK 5000

Product Code: 42148

The HULK 5000 treadmill is designed to be a comfortable and easy to use treadmill that looks great in any gym, public, or private. Powerful 3HP Continuous duty AC Motor (6HP Peak) with Taiwan designed Inverter.

- Motor : 3HP (6HP Peak) AC Continuous Duty
- Speed Range : 1.0~20km/h
- Incline : 0~15%
- Running Belt : 22x 62" (540x1575mm) 3.2mm, SIEGLING, Germany
- Display : LED Display
- Max. User Weight : 200 Kgs.
- Net Weight : 216 Kgs.
- Assembly (LxWxH) : 2400 x 910 x 1665mm
- Foldable : No
- Emergency Stop : Yes

ELECTRONICS

- Displays : Time, Speed, Distance, Calorie, Heart Rate, Emergency Stop, Power





AC Motor



Emergency stop



Motor Incline



Touch Screen



USB Port

CX-5T (Touchscreen)

Product Code: 42150

Outstanding design with Wide Running Area. Best suited for Semi-Commercial use, 2.0 HP AC Motor with 15" touch screen Display.

- Motor : 2HP (4 HP Peak) AC Continuous Duty
- Speed Range : 1.0~20.8 Kph.
- Incline : Motor Incline 0~18%
- Running Belt : 23 x 59" (580x1500mm)
- Display : 15" Touchscreen Display
- Max. User Weight : 150 Kgs.
- Net Weight : 140 Kgs.
- Assembly (LxWxH) : 1956 x 1022 x 1393mm
- Foldable : Yes
- Emergency Stop : Yes

ELECTRONICS

- Functions : Mp3 and USB, 5 Pre-set, 1 user programs
- Displays : Time, Speed, Distance, Pulse, Calories, Body Fat

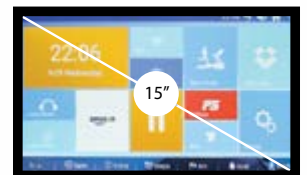

**BIG
SCREEN DISPLAY**

AC
MotorEmergency
stopMotor
InclineUSB
Port

CX-5

Product Code: 42110

Outstanding design with Wide Running Area. Best suited for Semi-Commercial use, 2.0 HP AC Motor with LED Window Displays : Speed, Distance, Time, Calories, Program, Level, Pulse, Heart Rate, Body Fat. Light Weight Aluminium Alloy Side Posts.

- Motor : 2HP (4 HP Peak) AC Continuous Duty
- Speed Range : 1.0~20.8 Kph.
- Incline : Motor Incline 0~18%
- Running Belt : 23 x 59" (580x1500mm)
- Display : 7 LED Windows
- Max. User Weight : 150 Kgs.
- Net Weight : 140 Kgs.
- Assembly (LxWxH) : 1956 x 1022 x 1393mm
- Foldable : Yes
- Emergency Stop : Yes

ELECTRONICS

- Functions : Mp3 and USB, 5 Pre-set programs, 1 user
- Displays : Time, Speed, Distance, Pulse, Calories, Body Fat





AC Motor



Emergency stop



Motor Incline



Fan



USB Port

AC 800X

Product Code: 42111

AC Motor Treadmill with (-) 3% to 15% Incline. The (-) Negative Incline to experience Walking Downhill which Develops Eccentric contractions. As you walk downhill, your body gains momentum. These eccentric contractions build strength throughout these muscles' ranges of motion. It has powerful Motor, good allround Performance in Semi-Commercial environment.

- Motor : 2.5 HP (5 HP Peak) AC Duty
- Speed Range : 1.0~20 Kph.
- Incline : -3~15% Motor Incline
- Running Belt : 22 x 60"(560 x 1530mm)
- Display : 7 LCD Display with Back Blue Light
- Max. User Weight : 150 Kgs.
- Net Weight : 110 Kgs.
- Assembly (LxWxH) : 2080 x 900 x 1460mm
- Foldable : Yes
- Emergency Stop : Yes
- Other Features : Negative Incline for Downhill walking Effect

ELECTRONICS

- Functions : 2 Layer Running Deck with Cushion, Incline Button on Handle Bar, USB and Speaker
- Displays : Speed, Distance, Time, Calories, Heart Pulse, Program

3%
Negative
Incline



AC
MotorEmergency
stopMotor
Incline

Fan

USB
Port

AC 700X

Product Code: 42112

Strong 2 HP AC Motorised Treadmill Suitable for for Semi-Commercial Environment. Double Deck Cushioning which is Highly Recommended for Comfort Level for Joints.

- Motor : 2.0 HP (4 HP Peak) AC Duty
- Speed Range : 1~18 Kph.
- Incline : Motor Incline 0~15%
- Running Belt : 20 x 55" (510 x 1400 mm)
- Display : 5 LED Readout
- Max. User Weight : 140 Kgs.
- Net Weight : 85 Kgs.
- Assembly (LxWxH) : 2070 x 880 x 1335mm
- Foldable : Yes
- Emergency Stop : Yes

ELECTRONICS

- Functions : 2 Layer Running Deck with Cushion, Quick Speed/ Incline Button with FAN and Hand Pulse. Running Surface with Shock Dissipation System, 12 Pre-set Programs, 4 HRC, 3 User, Anti Skid Rail. Double Cushion Deck, Wheels for Transport, MP3 and USB
- Displays : Speed, Distance, Time, Calories, Pulse, Body Fat



AC 90

Product Code: 42155

AC90 semi commercial AC motor treadmill is a great choice for those who want a high-quality treadmill with wide range of features and benefits, including a powerful motor, a large running surface, and a variety of programs and settings.

- Motor : 3.0 HP (6 HP Peak) AC Duty
- Speed Range : 1~24 Kph.
- Incline : Motor Incline 0~20%
- Running Belt : 23 x 60" (580x1500mm)
- Max. User Weight : 150 Kgs.
- Net Weight : 106 Kgs.
- Assembly (LxWxH) : 2050x840x1420mm
- Emergency Stop : Yes

ELECTRONICS

- Functions : Manual program+24 Built-in workout programs+Body Fat MP3 and USB, FITSHOW app
- Displays : Speed, Incline, Distance, Time, Calories, Pulse, Heart Rate



AC
MotorEmergency
stopMotor
Incline

Fan

USB
Port

AC 65

Product Code: 42154

AC65 semi commercial AC motor treadmill is a great choice for those who want a high-quality treadmill with wide range of features and benefits, including a powerful motor, a large running surface, and a variety of programs and settings.

- Motor : 2.0 HP (4 HP Peak) AC Duty
- Speed Range : 1~24 Kph.
- Incline : Motor Incline 0~20%
- Running Belt : 23 x 59" (580x1500mm) 1.8mm thick
- Display : 7" LCD with Blue Backlit
- Max. User Weight : 150 Kgs.
- Net Weight : 106 Kgs.
- Assembly (LxWxH) : 2050x840x1420mm
- Emergency Stop : Yes

ELECTRONICS

- Functions : Manual program+24 Built-in workout programs+Body Fat MP3 and USB, Fan
- Displays : Speed, Incline, Distance, Time, Calories, Pulse, Body fat





POWER 790M

Product Code: 42628

State of art latest design elliptical crosstrainer with electronic incline function. Extra long stride for multiple users self generating electronics with adaptor power supply. LED light makes it stand out with a striking appeal. Robust and Sturdy construction makes it for commercial use.

- Stride Length : 23 inch (590mm)
- Flywheel : 15 Kgs.
- Display : 7 Windows LED Display
- Slope Range : 0~20 grade (15~32°)
- Resistance : 1-20 Electromagnetic resistance
- Max. User Weight : 180 Kgs.
- Net Weight : 167 Kgs.
- Assembly (LxWxH) : 2210 x 710 x 1660 mm

ELECTRONICS

- Displays : 7 Windows + 1 Dot Matrix Watt, Speed, Calories, RPM, Distance, Heart Rate, LAP, Contact, Pulse, 8 Programs, Contact Heart Rate Handles, Pedals with Cushioned Gel
- Power Supply : External Power adaptor Required.
- Generator : Self Generating Electronics



STRIDE
590mm



Wireless Phone Charger

RE-500

Product Code: 42626

Non-Impact Conditioning—The elliptical allows your body to emulate a running motion without causing the strenuous impact on your joints. Therefore, the elliptical can burn close to the same amount of calories with less effort and long time injuries. Comfortable pedals with cushioned Gel.

- Stride Length : 21 inch (533mm)
- Resistance Level : 350w, 20 level
- Max. User Weight : 160 Kgs.
- Net Weight : 119 Kgs.
- Assembly (LxWxH) : 2179 x 742 x 1610 mm

ELECTRONICS

- Displays : 7 Windows + Dot Matrix, Time, Speed, Calories, RPM, Distance, Heart Rate
- Power Supply : No External Power Supply Required.
- Generator : Self Generating Electronics



STRIDE
533mm

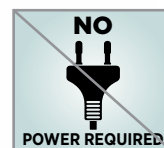

E-70 (Taiwan)

Product Code: 42601

E70 Elliptical Offers a Wonderful Workout Solution by using a Long Pedal Arm to help Exercisers to Smoothly Train the Whole Body at a Natural and Fluid Ergonomic Position, it is also Equipped with Heavy Flywheel to Maintain a Smooth Action and Ensure a Comfortable Workout.

- Stride Length : 500mm
- Flywheel : 242 mm (14.5 Kgs.)
- Display : 5 LED Readout
- Resistance Level : 40
- Transmission/Ratio : V-Belt / 1:10.3
- Max. User Weight : 200 Kgs.
- Net Weight : 104 Kgs.
- Assembly (LxWxH) : 2060 x 795 x1760 mm

ELECTRONICS

- Displays : Time, Distance, METS, Pulse, Calories with 4 Pre set, 4 HRC, 1 Manual Program
- Power Supply : No External Power Supply Required.
- Generator : Self Generating Electronics



STRIDE
500mm



CE-80

Product Code: 42603

CE-80 is a commercial grade Elliptical comes with rear flywheel. It's long and robust design makes it very comfortable even for tall users.

- Stride Length : 500mm
- Flywheel : 242 mm (14.5 Kgs.)
- Resistance Level : 1~20
- Transmission | Ratio : V-Belt | 1:10.3
- Max. User Weight : 200 Kgs.
- Net Weight : 130 Kgs.
- Assembly (LxWxH) : 2200 x 730 x 1560 mm

ELECTRONICS

- Displays : Time, RPM, Distance, Pulse, METS, Calories with 4 Pre set, 4 HRC, 1 Manual Program
- Power Supply : No External Power Supply Required.



STRIDE
500mm



28 FE

Product Code: 42633

28 FE is a commercial grade Elliptical comes with front flywheel. It's long and robust design makes it very comfortable even for tall users.

- Stride Length : 460mm (18")
- Flywheel : 14.0 Kgs. 2 Way
- Resistance Level : 20
- Crank : Disc
- Display : LCD Screen
- Max. User Weight : 135 Kgs.
- Net Weight : 91.5 Kgs.
- Assembly (LxWxH) : 1890 x 560 x 1610 mm

ELECTRONICS

- Displays : Time, Speed, RPM, Distance, Pulse, Calories, Recovery, Body Fat
- Power Supply : No External Power Supply Required.



STRIDE
460mm



CD5E

Product Code: 42630

Semi-Commercial Elliptical with 7 Kgs. Magnetic Flywheel. 5 inch LCD Display Screen. 0~15 % 3 Step Manual Incline. 20 inches Stride Length. Bluetooth and Tablet/ Phone Holder.

- Stride Length : 20" (508mm)
- Incline : 0~15% (3 Steps Manual)
- Flywheel : 10 Kgs. Magnetic
- Display : 5" LCD
- Resistance Level : 24 Level
- Max. User Weight : 130 Kgs.
- Net Weight : 91 Kgs.
- Assembly (LxWxH) : 1800 x 550 x 850mm

ELECTRONICS

- Functions : 12 Programs, Handle Pulse Sensor, Bluetooth
- Displays : Time, Speed, Distance, Pulse, Calories

 Bluetooth™

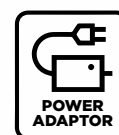

CNB-9.0ES AT* (Taiwan)**Product Code: 42627**

CE-80 Elliptical Offers a Wonderful Workout Solution by using a Long Pedal Arm to help Exercisers to Smoothly Train the Whole Body at a Nature and Fluid Ergonomic Position, it is also Equipped with Heavy Flywheel to Maintain a Smooth Action and Ensure a Comfortable Workout.

- Stride Length : 18" (450mm)
- Flywheel : 260mm, Two Way
- Crank : 3 Pcs
- Resistance Level : 1~20
- Transmission | Ratio : V-Belt | 1:10.3
- Max. User Weight : 136 Kgs.
- Net Weight : 76 Kgs.
- Assembly (LxWxH) : 1620 x 620 x 1590 mm

ELECTRONICS

- Displays : Time, Speed, Distance, Calories, Pulse, Recovery, Body Fat, RPM, Manual, H.R.C., 25 Programs, User Profile, Watt program
- Power Supply : External Power Supply Required.

***AT = Auto Tension**

STRIDE
450mm



FitLux
Taiwan

FITLUX 5200

Product Code : 49001

FitLux 5200 elliptical cross trainer is designed to engage all the muscles of the lower and upper body while minimizing strain on the back, joints and muscles. Constructed from extra-heavy-gauge steel and equipped at all pivot points with sealed bearings provides a comfortable and natural stride. Fitlux 5200 elliptical trainer features a quiet, smooth belt drive system, 16 preset programs including heart rate control options, 16 levels of resistance, a body-fat calculator and built-in heart rate receiver.

- Stride Length : 19" (483mm)
- Flywheel : 270 mm Dia.
- Crank : 3 Pcs
- Max. User Weight : 140 Kgs.
- Net Weight : 73 Kgs.
- Assembly (LxWxH) : 2000 x 640 x 1660mm

ELECTRONICS

- Functions : Motorised Resistance 16 Ranges, 16 Program, 3 HRC, 6 Pre-Set, 4 User, 1 Body Fat,
- Displays : RPM, Time, Speed, Distance, Calories, Pulse, Watt, Recovery.



28E

Product Code: 42632

28E is a Deluxe Elliptical comes with rear flywheel. It's long and robust design makes it very comfortable even for tall users.

- Stride Length : 460mm (18")
- Flywheel : 10.0 Kgs.
- Resistance Level : 25
- Display : LCD Screen
- Max. User Weight : 135 Kgs.
- Net Weight : 81 Kgs.
- Assembly (LxWxH) : 2050 x 700 x 1730 mm

ELECTRONICS

- Displays : Time, Speed, Incline, Watt, Distance, Pulse, Calories, Recovery, Body Fat



STRIDE
460mm

EKX-6R

Product Code: 42615

Deluxe Elliptical Bike with 292mm dia. Flywheel. Stride Length 460mm.
Semi-Commercial Duty Elliptical with 24 Range Motorised Resistance.

- Stride Length : 18" (460mm)
- Flywheel : 292mm
- Resistance Level : 24 Range Motorised
- Max. User Weight : 120 Kgs.
- Net Weight : 57 Kgs.
- Assembly (LxWxH) : 1707 x 686 x 1625mm

ELECTRONICS

- Functions : 12 Programs with 4 HR
- Displays : Time, Speed, Distance, Pulse, Calories, Watt, Recovery



STRIDE
460mm

POWER 290

Product Code: 42345

Self Powered Hybrid Upright Bike with No External Power Required. It has 3 riding positions with contact heart rate Grips. Single sided weighted pedal. Ergonomically designed handle bars. K-O-P-S biometrics, Easy to service.

- Flywheel : 15 Kgs.
- Resistance Level : 1~40 Electromagnetic resistance
- Display : 7 Windows LED Display
- Brake : Self Powered Hybrid Brake
- Max. User Weight : 180 Kgs.
- Net Weight : 72 Kgs.
- Assembly (LxWxH) : 1200 x 580 x 1550mm

ELECTRONICS

- Maintenance-free : Fault self-inspection system, machine failure occurs, automatic display fault code
- Functions : USB interface, input subtitles, advertising language function, mobile phone holder, 11 seat adjustable position, Machine will enter sleep mode in 5 minutes under standby condition
- System program : 6 built-in, 3 user, 3 counting programs
- MFT function : Automatically calculates the metabolic equivalent index of exercise energy
- Step counting : Automatically counts the number of movement steps and displays the step frequency data
- Displays : 7 Windows + Dot Matrix Watt, Speed, Calories, RPM, Distance, Heart Rate, LAP, Contact, Pulse, 8 Programs, Contact Heart Rate Handles, Pedals with Cushioned Gel



RU 500

Product Code: 42300

Self Powered Hybrid Upright Bike with No External Power Required. It has 3 riding positions with contact heart rate Grips. Single sided weighted pedal. Ergonomically designed handle bars. K-O-P-S biometrics, Easy to service.

- Pulley : One Way Pulley Ø300mm
- Crank : Standard
- Flywheel : 8 Kgs.
- Resistance Level : 350W, 20 Level
- Display : 7 Windows + Dot Matrix
- Brake : Self Powered Hybrid Brake
- Max. User Weight : 160 Kgs.
- Net Weight : 63 Kgs.
- Assembly (LxWxH) : 1090 x 660 x 1490mm

ELECTRONICS

- Functions : Instant program key, 11 workout and 7 display readouts. It has 3 riding positions with contact heart rate Grips. It has 2 step powder coating with rust resistance undercoat. Single sided weighted pedal.
- Displays : Watts, Speed, Time, Calorie, RPM, Distance, Heart, Rate, Lap, Readout.

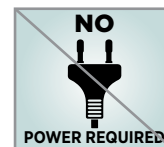

CNB6.0 U-AT* (Taiwan)**Product Code: 42330**

Programmable Upright Bike with BELT DRIVE System. 260mm Dia. Flywheel. Auto Tension. Friction-free Magnetic Resistance. Deluxe computer console with book racket. Built-in Hand Grip Pulse Sensor with Elbow Pads. Two-Tones Pedals with shock resistance and adjustable strap.

- Flywheel : 260mm (7 Kgs.)
- Crank : 3 Pcs
- Resistance Level : 16 Fitness Levels
- Pulley : Ø300
- Max. User Weight : 150 Kgs.
- Net Weight : 46 Kgs.
- Assembly (LxWxH) : 1220 x 540 x 1470mm
- Other Features : Auto Tension, Pulse Recovery +BACK LIGHT

ELECTRONICS

- Functions : 12 Programs
- Displays : Time, RPM, Speed, Distance, Watts, Calories, H.R.C., Body Fat, Pulse, BMI
- Generator : Friction-free Magnetic Resistance.

***AT = Auto Tension**

Belt Drive

28U

Product Code: 42352

Semi-Commercial Duty Upright Bike 3 Pcs Crank. Friction Free Electromagnetic Resistance with adaptor. It has LED display.

- Flywheel : 9 Kgs. One way
- Crank : 3 Pcs
- Resistance Level : 24
- Display : LED Screen
- Max. User Weight : 135 Kgs.
- Net Weight : 50.5 Kgs.
- Assembly (LxWxH) : 1245 x 620 x 1450mm
- **ELECTRONICS**
- Functions : 12 Level short Keys
- Displays : Time, Speed, Distance, Calories, Pulse



170U

Product Code: 42341

Semi-Commercial Duty Upright Bike 3 Pcs Crank. Friction Free Electromagnetic Resistance with adaptor. It has dual colour LCD display with tablet/phone holder and built in fan.

- Flywheel : 6 Kgs.
- Crank : 3 Pcs
- Display : Dual Colour LCD
- Max. User Weight : 150 Kgs.
- Net Weight : 39 Kgs.
- Assembly (LxWxH) : 1120 x 620 x 1400mm
- **ELECTRONICS**
- Functions : 12 Preset, Program, Mp3 with built in speaker
- Displays : Time, Speed, Distance, Calories, Pulse, Recovery, RPM, Watts, H.R.C.



Belt Drive

POWER 390

Product Code: 42346

Self Powered Hybrid Upright Bike with No External Power Required. It has 3 riding positions with contact heart rate Grips. Single sided weighted pedal. Ergonomically designed handle bars. K-O-P-S biometrics, Easy to service.

- Flywheel : 15 Kgs.
- Resistance Level : 1~40 Electromagnetic resistance
- Display : 7 Windows LED Display
- Brake : Self Powered Hybrid Brake
- Max. User Weight : 180 Kgs.
- Net Weight : 72 Kgs.
- Assembly (LxWxH) : 1770 x 750 x 1450mm

ELECTRONICS

- Maintenance-free : Fault self-inspection system, machine failure occurs, automatic display fault code
- Functions : USB interface, 11 seat adjustable position
- System program : 6 built-in, 3 user, 3 counting programs
- MFT function : Automatically calculates the metabolic equivalent index of exercise energy
- Step counting : Automatically counts the number of movement steps and displays the step frequency data
- Displays : 7 Windows + Dot Matrix Watt, Speed, Calories, RPM, Distance, Heart Rate, LAP, Contact, Pulse, 8 Programs, Contact Heart Rate Handles, Pedals with Cushioned Gel

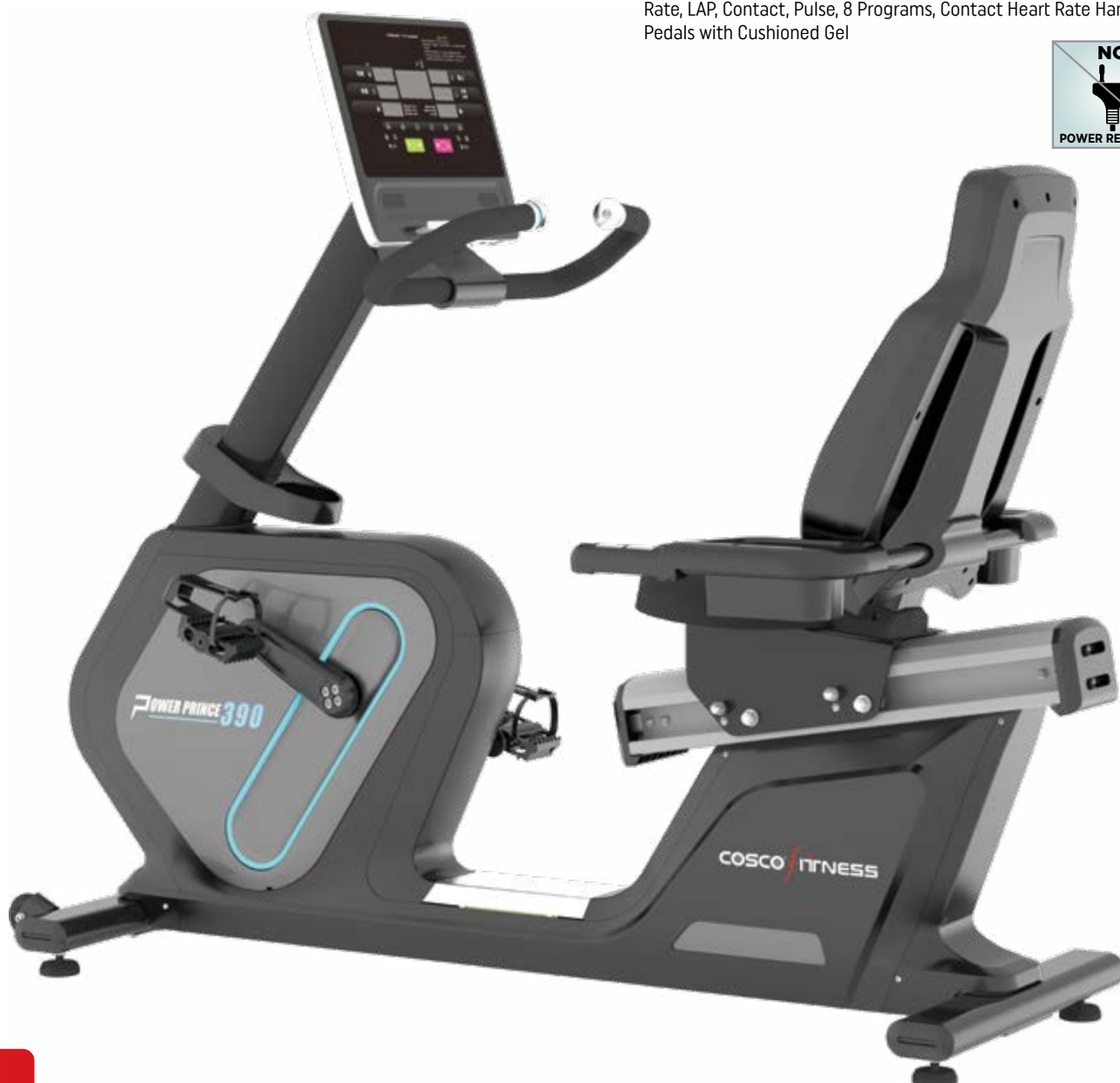



RR-500

Product Code: 42306

Self Powered Hybrid Recumbent Bike with No External Power Required. Walk through design, easy to service. It has 3 riding positions with contact heart rate grips on your finger tips control. Single sided weighted pedal. It has 2 step powder coating with rust resistance undercoat.

- Pulley : One Way Pulley Ø300mm
- Crank : Standard
- Resistance Level : 350W, 20 Level
- Display : 7 Windows + Dot Matrix
- Brake Type : Self Powered Hybrid Brake
- Flywheel : 9 Kgs.
- Max. User Weight : 160 Kgs.
- Net Weight : 79 Kgs.
- Assembly (LxWxH) : 1640 x 750 x 1240mm

ELECTRONICS

- Functions : 6 Pre-set Programs, 2 Custom Programs + 3 HRC, Quick Start Program, Pulse Reading, Low Profile Design, 20 Levels of Intensity, K-O-P-S biomechanics.
- Displays : Windows Dot Matrix LED with Watts, Speed, Time, Calorie, RPM, Distance, Heart Rate, Lap, Readout.



C-1000 R AT* (Taiwan)

Product Code: 42308

Commercial Duty Recumbent Bike with Ø300mm Oneway Pulley and 3 Pcs Crank. Friction Free Electromagnetic Resistance with adaptor. Deluxe Computer Console. Adjustable Deluxe Aluminium Carriage Tube and Seat Carriage.

- Pulley : One Way Pulley Ø300mm
- Crank : 3 Pcs
- Displays : LED Readabouts
- Max. User Weight : 150 Kgs.
- Net Weight : 47 Kgs.
- Assembly (LxWxH) : 1450 x 620 x 1280mm

ELECTRONICS

- Functions : Large Adjustable Seat & Back Cushions, Programmable Computer Features Programs with Large Windows LED Readout, Built-in Hand Grip Pulse Sensor, Durable Pedals with Shock-Absorbing Air Cushion and Adjustable Strap / Strap Adjuster Buckle, Extra Sturdy and Stable Steel Frame Construction.
- Power Supply : External Power Supply Required.

***AT = Auto Tension**



28R

Product Code: 42353

Recumbent Bike with Oneway Pulley and 3 Pcs Crank. Friction Free Electromagnetic Resistance.

- Flywheel : 9 Kgs. One Way
- Crank : 3 Pcs
- Resistance Level : 24
- Displays : LED Readabouts
- Max. User Weight : 150 Kgs.
- Net Weight : 71 Kgs.
- Assembly (LxWxH) : 2010 x 640 x 1240mm

ELECTRONICS

- Functions : Quick release seat sliding, comfortable mesh back, incline adjustment, 12 level short keys 27 programs.



POWER 980

Product Code: 42348

Commercial grade bike with 20 Kgs. Aluminium flywheel, belt driven, silent motion, magnetic control resistance.

- Flywheel : 20 Kgs. Aluminium Flywheel
- Max. User Weight : 180 Kgs.
- Net Weight : 68 Kgs.
- Assembly (LxWxH) : 1200 x 580 x 1550mm
- Other Features : Automatic speed changing



Belt Drive

REVO TF5

Product Code: 42355

Commercial grade bike, 20 Kgs. balanced flywheel and 21.5" TFT Screen with app., belt driven, silent motion, magnetic control resistance.

- Flywheel : 20 Kgs.
- Display : 21.5" TFT Screen with app.
- Resistance Level : 36
- Max. User Weight : 150 Kgs.
- Net Weight : 60 Kgs.
- Assembly (LxWxH) : 1310 x 535 x 1295mm



POWER 880

Product Code: 50013

CNC 22 kg flywheel, one-piece belt driven bike. High strength axle and foot pedal which lengthen the service life. Smooth and silent when riding.

- Flywheel : 22 Kgs. CNC Flywheel
- Brake : Press Type
- Max. User Weight : 180 Kgs.
- Net Weight : 57 Kgs.
- Assembly (LxWxH) : 1050 x 600 x 1150mm
- Other Features : High grade pedal, adjust seat forwards & back, upward & downward, high strength axle & foot pedal, smooth & silent ride



Belt Drive

GYRO-XB 06

Product Code: 50014

Magnetic Bike with large and comfortable handlebar provide steady supporting during exercise, with thoughtful design of places for Cellphone and Water Bottles. Comfortable seat with dynamical and human biological design. Pedal with fixation to protect the feet during exercise. Emergency button could pushed to stop the bike at once, which improve the security index of this bike. Brake system to control the degree of resistance.

- Flywheel : 16 Kgs. balanced
- Brake : Press Type
- Max. User Weight : 160 Kgs.
- Net Weight : 70 Kgs.
- Assembly (LxWxH) : 1225 x 630 x 1170mm
- Other Features : 3mm thickness oval tube: electrostatic powder coating, raw materials from South Korea, Laser Cutting equipment from Germany, Robot welding machines from Japan

ELECTRONICS

- Displays : Time, Distance, Heart Rate



Belt Drive

GROUP CYCLING BIKE



REVO F5

Product Code: 42354

Self Powered Hybrid Bike with No External Power Required
Commercial grade bike, 20 Kgs. balanced flywheel and
LED Display, belt driven, silent motion, Bluetooth with app.

- Flywheel : 20 Kgs.
- Display : LED Screen
- Resistance Level : 36
- Max. User Weight : 150 Kgs.
- Net Weight : 60 Kgs.
- Assembly (LxWxH) : 1310 x 535 x 1295mm



LED Display



REVO 220

Product Code: 42312

New age Design, Revo 220 is a Commercial Indoor Group Cycle with Rubber Coated Handlebars Makes Users feel more Comfortable. Belt Drive System. Micro-adjustable Fore and AFT Seat Slider.

- Flywheel : 24Kgs. balanced
- Max. User Weight : 160 Kgs.
- Net Weight : 88 Kgs.
- Assembly (LxWxH) : 1250 x 600 x 1150mm
- Other Features : High grade pedal, adjustable forward AFT. Seat, Rubber coated handle bar

ELECTRONICS

- Displays : Time, Distance, Heart Rate



Belt Drive





REVO 718

Product Code: 42358

Commercial grade bike, 18 Kgs. balanced flywheel, belt driven, silent motion, high grade pedal, adjustable forward AFT. seat.

- Flywheel : 18 Kgs.
- Max. User Weight : 150 Kgs.
- Net Weight : 56 Kgs.
- Assembly (LxWxH) : 1060 x 240 x 780mm



Belt Drive

REVO 713

Product Code: 42359

Commercial grade bike, 13 Kgs. balanced flywheel, belt driven, silent motion, high grade pedal, adjustable forward AFT. seat.

- Flywheel : 13 Kgs.
- Max. User Weight : 150 Kgs.
- Net Weight : 54 Kgs.
- Assembly (LxWxH) : 1100 x 280 x 960mm



Belt Drive



POWER 580

Product Code: 42298

Automatic electric design, multi-angle handrail handle, free operation more convenient; Intelligent heart rate monitoring, small footprint, mute magnetic wheel, front casters, position freely, side of the spontaneous electric light belt. 220 speed electric control resistance control system.

- Motor : Self generating electronics
- Flywheel : 15 Kgs.
- Display : 7 Window LED digital display
- Handle : Ergonomic handle with quick fingertip control
- Max. User Weight : 180 Kgs.
- Net Weight : 108 Kgs.
- Assembly (LxWxH) : 1770 x 750 x 1450mm

ELECTRONICS

- Functions : Hand hold heart rate/ USB charging/ Feature light belt / Self fault detection system
- Displays : Resistance, Speed, Distance, Time, Heart rate, Heat, Steps, Step Frequency, Power, MET



CTZ-007 - STAIR CLIMBER

Product Code: 42300

The stair climbing movement engages the large muscles in your legs to raise heart rate and burn more calories per minute than jogging. Stair Climbers can be adjusted for speed, resistance to make exercises more effective. In addition to the cardio benefit, Stair Climbers also provide a targeted workout to muscles throughout your lower half including the glutes, thighs, hips and abdominals making them an ideal total body training tool.

- Stair Depth : 235mm
- Stair Height : 205mm
- Stair Width : 555mm
- Running Speed : 24~164 Steps per Minute
- Display : Multi window LED Display
- Max. User Weight : 180 Kgs.
- Net Weight : 165 Kgs.
- Assembly (LxWxH) : 1390 x 727 x 1993mm



CEB-11 AIR BIKE

Product Code: 42351

Dual Drive (Belt + Chain) Magnetic Air Bike, Large Flywheel. Flat Belt, 3 Pc Crank. Aluminium SPD Pedals.

- Crank : 3PCS,
- Flywheel : 6 kgs.
- Fan : 24" Dia. Plastic Fan
- Resistance Level : 15 Level Air and Magnetic
- Display : LCD
- Max. User Weight : 100 Kgs.
- Net Weight : 49 Kgs.
- Assembly (LxWxH) : 1400 x 610 x 1260mm
- Other Features : Chain + Belt Drive (Double Drive), 2 wheels in the front for easy transport. Adjustable Footplates, hand grip can be adjusted to fit different users, Bottle Holder

ELECTRONICS

- Displays : Speed, Distance, Time, Calories, Pulse, Built in receiver, Watt



Chain Drive



Belt Drive



RX 100 (Taiwan) AIR | MAGNETIC ROWER

Product Code: 42800

The foldable RX 100 rowing machine has a double resistance system, because of this it gives the exact rowing experience and quality as the heavy air rowing machines in the gym. The heavy air system creates the base resistance and natural rowing experience. The magnetic system creates the extra exercise resistance. Ergonomic grip for added comfort. With a nice touch, you can open and close the ventilation of the air resistance as desired.



- Resistance Level : 24 Levels
- Frame : Aluminium
- Display : LCD
- Max. User Weight : 170 Kgs.
- Net Weight : 43.6 Kgs.
- Assembly (LxWxH) : 2370 x 500 x 910mm
- Other Features : Built-in Receiver, EMS Generator

ELECTRONICS

- Functions : 43 Programs, 25 Preset, 5 User, 4 HRC, 1 Watt
- Displays : Race, Recovery, User program, Time, Distance, Wattage, Speed, Scan, Number of Strokes, Calories, Ergometer, Body Fat, BMI Index

RX 99 (Taiwan) AIR | MAGNETIC ROWER

Product Code: 42801

The foldable RX-99 rowing machine is the ideal tool to improve your cardio endurance, weight loss and strengthen a wide range of muscles. The rowing machine is equipped with an extra strong aluminum rail with a high seat. In combination with a well-designed frame, ensures that you can step on your rowing machine with complete confidence.

- Resistance Level : 16 Levels
- Frame : Aluminium
- Display : LCD Backlight
- Max. User Weight : 130 Kgs.
- Net Weight : 36 Kgs.
- Assembly (LxWxH) : 2140 x 600 x 740mm
- Other Features : Polar Receiver

ELECTRONICS

- Functions : 16 Programs : 12 Preset, 4 HRC, 1 User Programs
- Displays : Race, Recovery, User program, Time, Distance, Speed, Number of Strokes, Calories
- Adaptor : 9V 1A



CRW-6018 WATER ROWER

Product Code: 42808

Fluid resistance rower workout theory

Drag Force is physics impact data in water tank tht drag the handlebar and provide a program to produce true Watt and Calories. Drag faster more resistance.

- Resistance Level : 6 Levels
- Sliding Track : Twin tube with aluminum rail
- Brake : Water tension
- Transmission System : Volute Spring / Bungee cord
- Max. User Weight : 150 Kgs.
- Net Weight : 35 Kgs.
- Assembly (LxWxH) : 2010 x 515 x 910mm
- Other Features : Polar Receiver

ELECTRONICS

- Functions : 16 Programs : 12 Preset, 4 HRC, 1 User Programs
- Displays : Time, 500m, Spm, Drag Force, Distance S, Strokes, Total Strokes, Calories, Watt, Bulit in Pulse Receiver, Quick Start, Standard, Target (Interval/Single), Custom, Race
- Adaptor : Battery (2*AA)

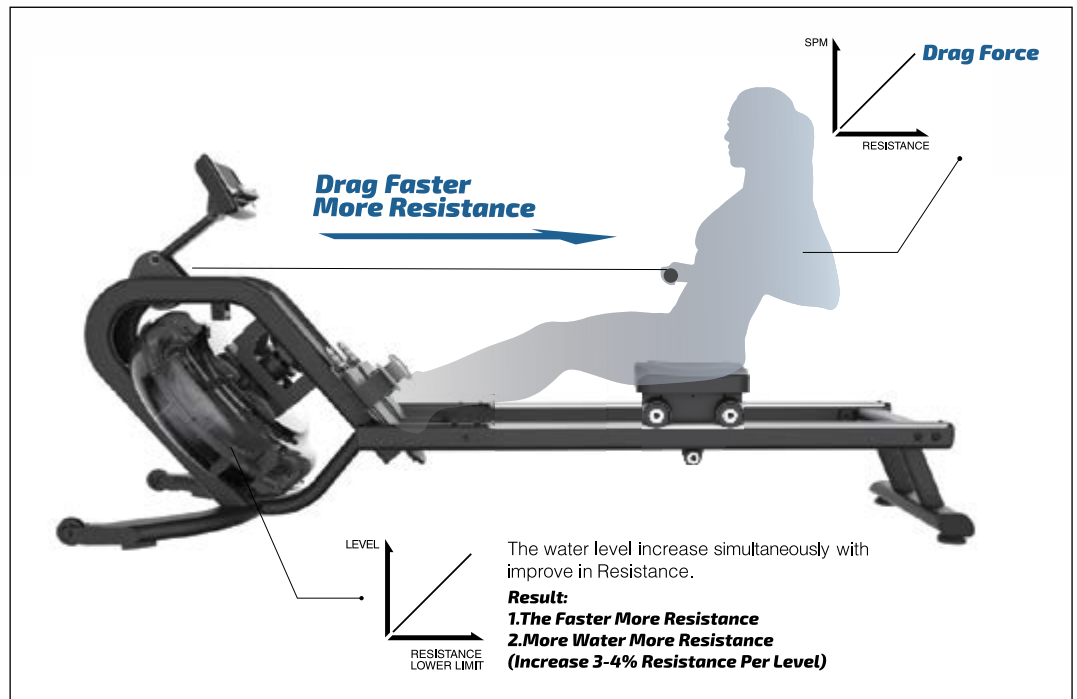



MAGNUM SINGLE STATION



CE 3001

PRONE LEG CURL

Product Code: 44500

Size (LxWxH) : 1520 x 990 x 1620 mm
 Net Weight : 216 Kgs.
 Weight Plates : 94 Kgs.
 Steel Tubing : 50 x 100 mm
 Steel Thickness : 2.5 mm
 Seat : High Density PU
 Weight Material : Cast Iron
 Cable : 6 mm Dia.

CE 3003

LEG PRESS

Product Code: 44502

Size (LxWxH) : 1900 x 1100 x 1620 mm
 Net Weight : 220 Kgs.
 Weight Plates : 109 Kgs.
 Steel Tubing : 50 x 100 mm
 Steel Thickness : 2.5 mm
 Seat : High Density PU
 Weight Material : Cast Iron
 Cable : 6 mm Dia.



CE 3002

LEG EXTENSION

Product Code: 44501

Size (LxWxH) : 1300 x 990 x 1350 mm
 Net Weight : 223 Kgs.
 Weight Plates : 109 Kgs.
 Steel Tubing : 50 x 100 mm
 Steel Thickness : 2.5 mm
 Seat : High Density PU
 Weight Material : Cast Iron
 Cable : 6 mm Dia.





CE 3006

SHOULDER PRESS

Product Code: 44503

Size (LxWxH) : 1850 x 1220 x 1320 mm
 Net Weight : 239 Kgs.
 Weight Plates : 109 Kgs.
 Steel Tubing : 50 x 100 mm
 Steel Thickness : 2.5 mm
 Seat : High Density PU
 Weight Material : Cast Iron
 Cable : 6 mm Dia.

CE 3008

VERTICAL PRESS

Product Code: 44505

Size (LxWxH) : 1320 x 1300 x 1350 mm
 Net Weight : 214 Kgs.
 Weight Plates : 109 Kgs.
 Steel Tubing : 50 x 100 mm
 Steel Thickness : 2.5 mm
 Seat : High Density PU
 Weight Material : Cast Iron
 Cable : 6 mm Dia.



CE 3013

INCLINE PRESS

Product Code: 44507

Size (LxWxH) : 2060 x 1350 x 1620 mm
 Net Weight : 215 Kgs.
 Weight Plates : 109 Kgs.
 Steel Tubing : 50 x 100 mm
 Steel Thickness : 2.5 mm
 Seat : High Density PU
 Weight Material : Cast Iron
 Cable : 6 mm Dia.



CE 3023

SEATED LEG CURL

Product Code: 44508

Size (LxWxH) : 1650 x 940 x 1350 mm
Net Weight : 220 Kgs.
Weight Plates : 109 Kgs.
Steel Tubing : 50 x 100 mm
Steel Thickness : 2.5 mm
Seat : High Density PU
Weight Material : Cast Iron
Cable : 6 mm Dia.

CE 3030

BICEPS | CAMBER CURL

Product Code: 44509

Size (LxWxH) : 1190 x 890 x 1620 mm
Net Weight : 158 Kgs.
Weight Plates : 64 Kgs.
Steel Tubing : 50 x 100 mm
Steel Thickness : 2.5 mm
Seat : High Density PU
Weight Material : Cast Iron
Cable : 6 mm Dia.



CE 3033

LONG PULL

Product Code: 44510

Size (LxWxH) : 2820 x 1090 x 2360 mm
Net Weight : 268 Kgs.
Weight Plates : 109 Kgs.
Steel Tubing : 50 x 100 mm
Steel Thickness : 2.5 mm
Seat : High Density PU
Weight Material : Cast Iron
Cable : 6 mm Dia.



CE 3035

PULL DOWN

Product Code: 44511

Size (LxWxH) : 1850 x 1090 x 2340 mm
 Net Weight : 248 Kgs.
 Weight Plates : 109 Kgs.
 Steel Tubing : 50 x 100 mm
 Steel Thickness : 2.5 mm
 Seat : High Density PU
 Weight Material : Cast Iron
 Cable : 6 mm Dia.

CE 3005

LATERAL RAISE

Product Code: 44547

Size (LxWxH) : 1300 x 860 x 1370 mm
 Net Weight : 220 Kgs.
 Weight Plates : 109 Kgs.
 Steel Tubing : 50 x 100 mm
 Steel Thickness : 2.5 mm
 Seat : High Density PU
 Weight Material : Cast Iron
 Cable : 6 mm Dia.



CE 3034

VERTICAL ROW

Product Code: 44548

Size (LxWxH) : 1550 x 1370 x 1600 mm
 Net Weight : 230 Kgs.
 Weight Plates : 109 Kgs.
 Steel Tubing : 50 x 100 mm
 Steel Thickness : 2.5 mm
 Seat : High Density PU
 Weight Material : Cast Iron
 Cable : 6 mm Dia.



MAGNUM

DUAL STATION

CE 3007

PEC FLY | REAR DELT

Product Code: 44504

Size (LxWxH) : 1240 x 990 x 2110 mm
Net Weight : 227 Kgs.
Weight Plates : 110 Kgs.
Steel Tubing : 50 x 100 mm
Steel Thickness : 2.5 mm
Seat : High Density PU
Weight Material : Cast Iron
Cable : 6 mm Dia.



CE 3009

DIP | CHIN ASSIST

Product Code: 44506

Size (LxWxH) : 1550 x 1370 x 2360 mm
Net Weight : 289 Kgs.
Weight Plates : 88 Kgs.
Steel Tubing : 50 x 100 mm
Steel Thickness : 2.5 mm
Seat : High Density PU
Weight Material : Cast Iron
Cable : 6 mm Dia.

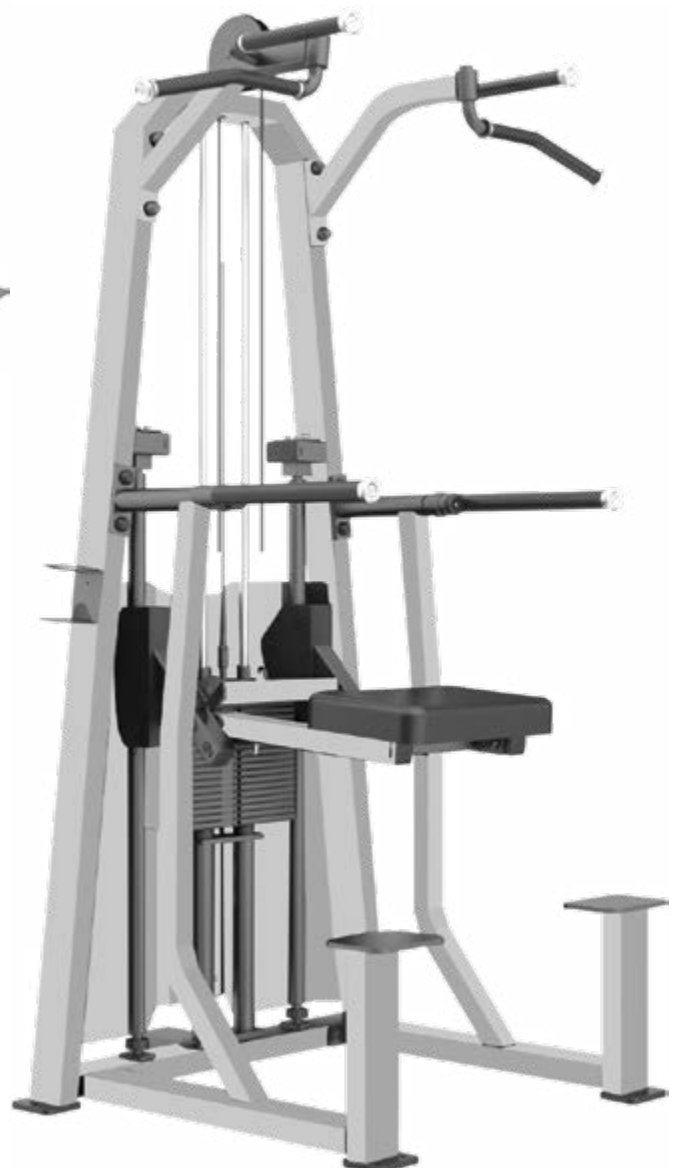

**CE 3085****LAT PULL | ROW****Product Code: 44550**

Size (LxWxH) : 1970 x 1350 x 2240 mm
 Net Weight : 262 Kgs.
 Weight Plates : 110 Kgs.
 Steel Tubing : 50 x 100 mm
 Steel Thickness : 2.5 mm
 Seat : High Density PU
 Weight Material : Cast Iron
 Cable : 6 mm Dia.

CE 3084**CHEST | SHOULDER PRESS****Product Code: 44549**

Size (LxWxH) : 1755 x 1380 x 1630 mm
 Net Weight : 297 Kgs.
 Weight Plates : 110 Kgs.
 Steel Tubing : 50 x 100 mm
 Steel Thickness : 2.5 mm
 Seat : High Density PU
 Weight Material : Cast Iron
 Cable : 6 mm Dia.





CE 3086

LEG EXTENSION | LEG CURL

Product Code: 44551

- Size (LxWxH) : 1650 x 1030 x 1630 mm
- Net Weight : 272 Kgs.
- Weight Plates : 110 Kgs.
- Steel Tubing : 50 x 100 mm
- Steel Thickness : 2.5 mm
- Seat : High Density PU
- Weight Material : Cast Iron
- Cable : 6 mm Dia.



CE 3087

BICEP | TRICEP

Product Code: 44554

- Size (LxWxH) : 1430 x 1000 x 1630 mm
- Net Weight : 262 Kgs.
- Weight Plates : 110 Kgs.
- Steel Tubing : 50 x 100 mm
- Steel Thickness : 2.5 mm
- Seat : High Density PU
- Weight Material : Cast Iron
- Cable : 6 mm Dia.

**CE 3088****AB | BACK****Product Code: 44552**

Size (LxWxH) : 1600 x 990 x 1630 mm
 Net Weight : 261 Kgs.
 Weight Plates : 110 Kgs.
 Steel Tubing : 50 x 100 mm
 Steel Thickness : 2.5 mm
 Seat : High Density PU
 Weight Material : Cast Iron
 Cable : 6 mm Dia.

CE 3089**ABDUCTOR | ADDUCTOR****Product Code: 44553**

Size (LxWxH) : 1550 x 860 x 1350 mm
 Net Weight : 245 Kgs.
 Weight Plates : 110 Kgs.
 Steel Tubing : 50 x 100 mm
 Steel Thickness : 2.5 mm
 Seat : High Density PU
 Weight Material : Cast Iron
 Cable : 6 mm Dia.



NITRO
SINGLE STATION



CE 5001
PRONE LEG CURL

Product Code: 44515

Size (LxWxH) : 1800 x 970 x 1500 mm
 Net Weight : 205 Kgs.
 Weight Plates : 94 Kgs.
 Steel Tubing : 50 x 100 mm
 Steel Thickness : 2.5 mm
 Seat : High Density PU
 Weight Material : Cast Iron
 Cable : 6 mm Dia.

CE 5003
LEG PRESS

Product Code: 44517

Size (LxWxH) : 1850 x 1050 x 1500 mm
 Net Weight : 255 Kgs.
 Weight Plates : 109 Kgs.
 Steel Tubing : 50 x 100 mm
 Steel Thickness : 2.5 mm
 Seat : High Density PU
 Weight Material : Cast Iron
 Cable : 6 mm Dia.



CE 5002
LEG EXTENSION

Product Code: 44516

Size (LxWxH) : 1400 x 1050 x 1500 mm
 Net Weight : 214 Kgs.
 Weight Plates : 109 Kgs.
 Steel Tubing : 50 x 100 mm
 Steel Thickness : 2.5 mm
 Seat : High Density PU
 Weight Material : Cast Iron
 Cable : 6 mm Dia.





CE 5006

SHOULDER PRESS

Product Code: 44518

- Size (LxWxH) : 1900 x 1350 x 1500 mm
- Net Weight : 231 Kgs.
- Weight Plates : 109 Kgs.
- Steel Tubing : 50 x 100 mm
- Steel Thickness : 2.5 mm
- Seat : High Density PU
- Weight Material : Cast Iron
- Cable : 6 mm Dia.

CE 5008

VERTICAL PRESS

Product Code: 44520

- Size (LxWxH) : 1400 x 1350 x 1500 mm
- Net Weight : 214 Kgs.
- Weight Plates : 109 Kgs.
- Steel Tubing : 50 x 100 mm
- Steel Thickness : 2.5 mm
- Seat : High Density PU
- Weight Material : Cast Iron
- Cable : 6 mm Dia.



CE 5023

SEATED LEG CURL

Product Code: 44522

- Size (LxWxH) : 1580 x 1050 x 1500 mm
- Net Weight : 220 Kgs.
- Weight Plates : 109 Kgs.
- Steel Tubing : 50 x 100 mm
- Steel Thickness : 2.5 mm
- Seat : High Density PU
- Weight Material : Cast Iron
- Cable : 6 mm Dia.



CE 5030
BICEP CURL

Product Code: 44523

- Size (LxWxH) : 1500 x 1300 x 1500 mm
- Net Weight : 194 Kgs.
- Weight Plates : 94 Kgs.
- Steel Tubing : 50 x 100 mm
- Steel Thickness : 2.5 mm
- Seat : High Density PU
- Weight Material : Cast Iron
- Cable : 6 mm Dia.

CE 5035
PULL DOWN

Product Code: 44525

- Size (LxWxH) : 1850 x 1090 x 2340 mm
- Net Weight : 248 Kgs.
- Weight Plates : 109 Kgs.
- Steel Tubing : 50 x 100 mm
- Steel Thickness : 2.5 mm
- Seat : High Density PU
- Weight Material : Cast Iron
- Cable : 6 mm Dia.



CE 5034
VERTICAL ROW

Product Code: 44524

- Size (LxWxH) : 1500 x 1300 x 1500 mm
- Net Weight : 194 Kgs.
- Weight Plates : 94 Kgs.
- Steel Tubing : 50 x 100 mm
- Steel Thickness : 2.5 mm
- Seat : High Density PU
- Weight Material : Cast Iron
- Cable : 6 mm Dia.

NITRO DUAL STATION



CE 5007

PEC FLY | REAR DELT

Product Code: 44519

Size (LxWxH)	: 1240 x 940 x 2110 mm
Net Weight	: 227 Kgs.
Weight Plates	: 109 Kgs.
Steel Tubing	: 50 x 100 mm
Steel Thickness	: 2.5 mm
Seat	: High Density PU
Weight Material	: Cast Iron
Cable	: 6 mm Dia.

CE 5009

DIP | CHIN ASSIST

Product Code: 44521

Size (LxWxH)	: 1550 x 1370 x 2360 mm
Net Weight	: 289 Kgs.
Weight Plates	: 88 Kgs.
Steel Tubing	: 50 x 100 mm
Steel Thickness	: 2.5 mm
Seat	: High Density PU
Weight Material	: Cast Iron
Cable	: 6 mm Dia.





CE 5084
CHEST | SHOULDER PRESS

Product Code: 44556

- Size (LxWxH) : 1755 x 1450 x 1510 mm
- Net Weight : 261 Kgs.
- Weight Plates : 110 Kgs.
- Steel Tubing : 50 x 100 mm
- Steel Thickness : 2.5 mm
- Seat : High Density PU
- Weight Material : Cast Iron
- Cable : 6 mm Dia.

CE 3085
LAT PULL | ROW

Product Code: 44550

- Size (LxWxH) : 1970 x 1350 x 2240 mm
- Net Weight : 262 Kgs.
- Weight Plates : 110 Kgs.
- Steel Tubing : 50 x 100 mm
- Steel Thickness : 2.5 mm
- Seat : High Density PU
- Weight Material : Cast Iron
- Cable : 6 mm Dia.



CE 5086
LEG EXTENSION | LEG CURL

Product Code: 44557

- Size (LxWxH) : 1650 x 1100 x 1510 mm
- Net Weight : 261 Kgs.
- Weight Plates : 110 Kgs.
- Steel Tubing : 50 x 100 mm
- Steel Thickness : 2.5 mm
- Seat : High Density PU
- Weight Material : Cast Iron
- Cable : 6 mm Dia.

**CE 5087****BICEP | TRICEP****Product Code: 44558**

Size (LxWxH) : 1430 x 1070 x 1510 mm
 Net Weight : 239 Kgs.
 Weight Plates : 110 Kgs.
 Steel Tubing : 50 x 100 mm
 Steel Thickness : 2.5 mm
 Seat : High Density PU
 Weight Material : Cast Iron
 Cable : 6 mm Dia.

CE 5088**AB | BACK****Product Code: 44559**

Size (LxWxH) : 1600 x 990 x 1630 mm
 Net Weight : 261 Kgs.
 Weight Plates : 110 Kgs.
 Steel Tubing : 50 x 100 mm
 Steel Thickness : 2.5 mm
 Seat : High Density PU
 Weight Material : Cast Iron
 Cable : 6 mm Dia.

**CE 5089****ABDUCTOR | ADDUCTOR****Product Code: 44560**

Size (LxWxH) : 1550 x 860 x 1350 mm
 Net Weight : 245 Kgs.
 Weight Plates : 110 Kgs.
 Steel Tubing : 50 x 100 mm
 Steel Thickness : 2.5 mm
 Seat : High Density PU
 Weight Material : Cast Iron
 Cable : 6 mm Dia.





ELITE SINGLE STATION



CJN 3001

PRONE LEG CURL

Product Code: 44568

Size (LxWxH) : 1660 x 950 x 1500 mm
 Net Weight : 190 Kgs.
 Weight Plates : 80 Kgs.
 Steel Tubing : 50 x 100 mm
 Steel Thickness : 2.5 mm
 Seat : High Density PU
 Weight Material : Cast Iron
 Cable : 6 mm Dia.

CJN 3002

LEG EXTENSION

Product Code: 44569

Size (LxWxH) : 1540 x 1030 x 1550 mm
 Net Weight : 200 Kgs.
 Weight Plates : 80 Kgs.
 Steel Tubing : 50 x 100 mm
 Steel Thickness : 2.5 mm
 Seat : High Density PU
 Weight Material : Cast Iron
 Cable : 6 mm Dia.





CYN 3003

LEG PRESS

Product Code: 44570

- Size (LxWxH) : 2090 x 1035 x 1550 mm
- Net Weight : 235 Kgs.
- Weight Plates : 94 Kgs.
- Steel Tubing : 50 x 100 mm
- Steel Thickness : 2.5 mm
- Seat : High Density PU
- Weight Material : Cast Iron
- Cable : 6 mm Dia.

CYN 3005

LATERAL RAISE

Product Code: 44571

- Size (LxWxH) : 1015 x 1135 x 1550 mm
- Net Weight : 173 Kgs.
- Weight Plates : 52 Kgs.
- Steel Tubing : 50 x 100 mm
- Steel Thickness : 2.5 mm
- Seat : High Density PU
- Weight Material : Cast Iron
- Cable : 6 mm Dia.



CYN 3008

VERTICAL PRESS

Product Code: 44572

- Size (LxWxH) : 1483 x 1060 x 1800 mm
- Net Weight : 210 Kgs.
- Weight Plates : 80 Kgs.
- Steel Tubing : 50 x 100 mm
- Steel Thickness : 2.5 mm
- Seat : High Density PU
- Weight Material : Cast Iron
- Cable : 6 mm Dia.

**CJN 3011****MULTI HIP****Product Code: 44573**

Size (LxWxH) : 1050 x 1310 x 1550 mm
 Net Weight : 255Kgs.
 Weight Plates : 80 Kgs.
 Steel Tubing : 50 x 100 mm
 Steel Thickness : 2.5 mm
 Seat : High Density PU
 Weight Material : Cast Iron
 Cable : 6 mm Dia.

CJN 3012**LAT PUL DOWN****Product Code: 44578**

Size (LxWxH) : 1880 x 1210 x 2330 mm
 Net Weight : 190 Kgs.
 Weight Plates : 80 Kgs.
 Steel Tubing : 50 x 100 mm
 Steel Thickness : 2.5 mm
 Seat : High Density PU
 Weight Material : Cast Iron
 Cable : 6 mm Dia.

**CJN 3018****ROTARY TORSO****Product Code: 44574**

Size (LxWxH) : 1110 x 1140 x 1550 mm
 Net Weight : 169 Kgs.
 Weight Plates : 65 Kgs.
 Steel Tubing : 50 x 100 mm
 Steel Thickness : 2.5 mm
 Seat : High Density PU
 Weight Material : Cast Iron
 Cable : 6 mm Dia.



CJN 3023

SEATED LEG CURL

Product Code: 44575

- Size (LxWxH) : 1645 x 1045 x 1550 mm
- Net Weight : 215Kgs.
- Weight Plates : 80 Kgs.
- Steel Tubing : 50 x 100 mm
- Steel Thickness : 2.5 mm
- Seat : High Density PU
- Weight Material : Cast Iron
- Cable : 6 mm Dia.

CJN 3028

TRICEP EXTENSION

Product Code: 44576

- Size (LxWxH) : 1145 x 940 x 1550 mm
- Net Weight : 148Kgs.
- Weight Plates : 49 Kgs.
- Steel Tubing : 50 x 100 mm
- Steel Thickness : 2.5 mm
- Seat : High Density PU
- Weight Material : Cast Iron
- Cable : 6 mm Dia.



CJN 3030

BICEP CURL

Product Code: 44577

- Size (LxWxH) : 1280 x 940 x 1550 mm
- Net Weight : 148Kgs.
- Weight Plates : 49 Kgs.
- Steel Tubing : 50 x 100 mm
- Steel Thickness : 2.5 mm
- Seat : High Density PU
- Weight Material : Cast Iron
- Cable : 6 mm Dia.

ELITE DUAL STATION



CJN 3007

REAR DELT | PEC FLY

Product Code: 44579

Size (LxWxH) : 1310 x 1220 x 2011 mm
 Net Weight : 200 Kgs.
 Weight Plates : 80 Kgs.
 Steel Tubing : 50 x 100 mm
 Steel Thickness : 2.5 mm
 Seat : High Density PU
 Weight Material : Cast Iron
 Cable : 6 mm Dia.

CJN 3009

DIP | CHIN ASSIST

Product Code: 44580

Size (LxWxH) : 1550 x 1370 x 2360 mm
 Net Weight : 200 Kgs.
 Weight Plates : 88 Kgs.
 Steel Tubing : 50 x 100 mm
 Steel Thickness : 2.5 mm
 Seat : High Density PU
 Weight Material : Cast Iron
 Cable : 6 mm Dia.





CJN 3021

ABDUCTOR | ADDUCTOR

Product Code: 44581

- Size (LxWxH) : 1550 x 925 x 1550 mm
- Net Weight : 223 Kgs.
- Weight Plates : 80 Kgs.
- Steel Tubing : 50 x 100 mm
- Steel Thickness : 2.5 mm
- Seat : High Density PU
- Weight Material : Cast Iron
- Cable : 6 mm Dia.

CJN 3084

CHEST | SHOULDER PRESS

Product Code: 44582

- Size (LxWxH) : 1730 x 1440 x 1550 mm
- Net Weight : 226 Kgs.
- Weight Plates : 80 Kgs.
- Steel Tubing : 50 x 100 mm
- Steel Thickness : 2.5 mm
- Seat : High Density PU
- Weight Material : Cast Iron
- Cable : 6 mm Dia.



CJN 3086

LEG EXTENSION | CURL

Product Code: 44584

- Size (LxWxH) : 1490 x 1020 x 1550 mm
- Net Weight : 225 Kgs.
- Weight Plates : 80 Kgs.
- Steel Tubing : 50 x 100 mm
- Steel Thickness : 2.5 mm
- Seat : High Density PU
- Weight Material : Cast Iron
- Cable : 6 mm Dia.

**CJN 3085****LAT PULL | ROW MACHINE****Product Code: 44583**

Size (LxWxH) : 1975 x 1370 x 2230 mm
 Net Weight : 195 Kgs.
 Weight Plates : 80 Kgs.
 Steel Tubing : 50 x 100 mm
 Steel Thickness : 2.5 mm
 Seat : High Density PU
 Weight Material : Cast Iron
 Cable : 6 mm Dia.

**CJN 3087****BICEP | TRICEP****Product Code: 44585**

Size (LxWxH) : 1320 x 1065 x 1550 mm
 Net Weight : 195 Kgs.
 Weight Plates : 80 Kgs.
 Steel Tubing : 50 x 100 mm
 Steel Thickness : 2.5 mm
 Seat : High Density PU
 Weight Material : Cast Iron
 Cable : 6 mm Dia.

**CJN 3088****AB | BACK EXTENSION****Product Code: 44586**

Size (LxWxH) : 1550 x 1090 x 1550 mm
 Net Weight : 215 Kgs.
 Weight Plates : 80 Kgs.
 Steel Tubing : 50 x 100 mm
 Steel Thickness : 2.5 mm
 Seat : High Density PU
 Weight Material : Cast Iron
 Cable : 6 mm Dia.



STEALTH
SPECIAL PLATE LOADED



CD601-G02
BELT SQUAT

Product Code: 45115

- Size (LxWxH) : 2055 x 1690 x 1460mm
- Net Weight : 182 Kgs.
- Steel Tubing : 50 x 100mm
- Steel Thickness : 2.5mm
- Frame Colour : Black
- Seat Material : High Density PU
- Arms Colour : Yellow

CD602
POWER SMITH MACHINE (Dual)

Product Code: 45114

- Size (LxWxH) : 1880x 2010 x 1750mm
- Net Weight : 165 Kgs.
- Steel Tubing : 50 x 100mm
- Steel Thickness : 2.5mm
- Frame Colour : Black
- Seat Material : High Density PU
- Arms Colour : Yellow



CD607
DOUBLE DEADLIFT

Product Code: 45116

- Size (LxWxH) : 1870 x 2045 x 500mm
- Net Weight : 103 Kgs.
- Steel Tubing : 50 x 100mm
- Steel Thickness : 2.5mm
- Frame Colour : Black
- Seat Material : High Density PU
- Arms Colour : Yellow





CD608
CHEST BUTTERFLY

Product Code: 45117

Size (LxWxH) : 1570 x 1630 x 970mm
Net Weight : 105 Kgs.
Steel Tubing : 50 x 100mm
Steel Thickness : 2.5mm
Frame Colour : Black
Seat Material : High Density PU
Arms Colour : Yellow

CD610
CIRCULAR LAT PULL DOWN

Product Code: 45118

Size (LxWxH) : 1930 x 1860 x 2060mm
Net Weight : 195 Kgs.
Steel Tubing : 50 x 100mm
Steel Thickness : 2.5mm
Frame Colour : Black
Seat Material : High Density PU
Arms Colour : Yellow



CA615
PRECISION CHEST PRESS

Product Code: 45126

Size (LxWxH) : 1460 x 2060 x 1675mm
Net Weight : 210 Kgs.
Steel Tubing : 50 x 100mm
Steel Thickness : 2.5mm
Frame Colour : Black
Seat Material : High Density PU
Arms Colour : Yellow



CA601

POWER SQUAT

Product Code: 45119

Size (LxWxH) : 1560 x 1865 x 1560mm
 Net Weight : 235 Kgs.
 Steel Tubing : 50 x 100mm
 Steel Thickness : 2.5mm
 Frame Colour : Black
 Seat Material : High Density PU
 Arms Colour : Yellow

CA 616

VERTICAL LEG PRESS

Product Code: 45129

Size (LxWxH) : 2010 x 3140 x 2050mm
 Net Weight : 280Kgs.
 Steel Tubing : 50 x 100mm
 Steel Thickness : 2.5mm
 Frame Colour : Black
 Seat Material : High Density PU
 Arms Colour : Black



CA 611

INCLINE LINEAR ROW

Product Code: 45124

Size (LxWxH) : 1710 x 910 x 1210mm
 Net Weight : 147 Kgs.
 Steel Tubing : 50 x 100mm
 Steel Thickness : 2.5mm
 Frame Colour : Black
 Seat Material : High Density PU
 Arms Colour : Black





CA 610

PENDULUM SQUAT

Product Code: 45123

Size (LxWxH) : 2430 x 1410 x 1670mm
Net Weight : 205 Kgs.
Steel Tubing : 50 x 100mm
Steel Thickness : 2.5mm
Frame Colour : Black
Seat Material : High Density PU
Arms Colour : Black

CA 606

GLUTE BRIDGE BENCH

Product Code: 45113

Size (LxWxH) : 1930 x 1400 x 515mm
Net Weight : 117 Kgs.
Steel Tubing : 50 x 100mm
Steel Thickness : 2.5mm
Frame Colour : Black
Seat Material : High Density PU
Arms Colour : Black



CA 617

STANDING T-BAR ROW

Product Code: 45128

Size (LxWxH) : 2085 x 995 x 910mm
Net Weight : 100 Kgs.
Steel Tubing : 50 x 100mm
Steel Thickness : 2.5mm
Frame Colour : Black
Seat Material : High Density PU
Arms Colour : Black



CA 613

REVERSE HYPER EXTENSION

Product Code: 45125

Size (LxWxH) : 1550 x 1400 x 1230mm
 Net Weight : 105 Kgs.
 Steel Tubing : 50 x 100mm
 Steel Thickness : 2.5mm
 Frame Colour : Black
 Seat Material : High Density PU
 Arms Colour : Black

CA 605L

STANDING HIP THRUST

Product Code: 45112

Size (LxWxH) : 1303 x 1590 x 1440mm
 Net Weight : 95 Kgs.
 Steel Tubing : 50 x 100mm
 Steel Thickness : 2.5mm
 Frame Colour : Black
 Seat Material : High Density PU
 Arms Colour : Black



CA 612

INCLINE FLY

Product Code: 45127

Size (LxWxH) : 1650 x 1050 x 790mm
 Net Weight : 68 Kgs.
 Steel Tubing : 50 x 100mm
 Steel Thickness : 2.5mm
 Frame Colour : Black
 Seat Material : High Density PU
 Arms Colour : Black





CANON-II PLATE LOADED



CTG 05D

CHEST PRESS

Product Code: 44810

Size (LxWxH) : 1500 x 1200 x 1715mm
 Net Weight : 162 Kgs.
 Steel Tubing : 50 x 100mm
 Steel Thickness : 2.5mm
 Frame Colour : Black
 Seat Material : High Density PU
 Arms Colour : Yellow

CTG 15D

INCLINE CHEST PRESS

Product Code: 44811

Size (LxWxH) : 1540 x 1030 x 1685mm
 Net Weight : 197 Kgs.
 Steel Tubing : 50 x 100mm
 Steel Thickness : 2.5mm
 Frame Colour : Black
 Seat Material : High Density PU
 Arms Colour : Yellow





CTG 25D

LOW ROW

Product Code: 44813

- Size (LxWxH) : 1570 x 1290 x 1630mm
- Net Weight : 190 Kgs.
- Steel Tubing : 50 x 100mm
- Steel Thickness : 2.5mm
- Frame Colour : Black
- Seat Material : High Density PU
- Arms Colour : Yellow

CTG 30D

INCLINE LEVEL ROW

Product Code: 44814

- Size (LxWxH) : 1190 x 1380 x 1300mm
- Net Weight : 137 Kgs.
- Steel Tubing : 50 x 100mm
- Steel Thickness : 2.5mm
- Frame Colour : Black
- Seat Material : High Density PU
- Arms Colour : Yellow





CTG 35D
SHOULDER PRESS

Product Code: 44815

Size (LxWxH) : 1290 x 1260 x 1485mm
 Net Weight : 146 Kgs.
 Steel Tubing : 50 x 100mm
 Steel Thickness : 2.5mm
 Frame Colour : Black
 Seat Material : High Density PU
 Arms Colour : Yellow

CTG 60D
LEG EXTENSION

Product Code: 44817

Size (LxWxH) : 1250 x 1250 x 1170mm
 Net Weight : 135 Kgs.
 Steel Tubing : 50 x 100mm
 Steel Thickness : 2.5mm
 Frame Colour : Black
 Seat Material : High Density PU
 Arms Colour : Yellow



CTG 70D
BICEP CURL

Product Code: 44819

Size (LxWxH) : 1055 x 900 x 1000mm
 Net Weight : 140 Kgs.
 Steel Tubing : 50 x 100mm
 Steel Thickness : 2.5mm
 Frame Colour : Black
 Seat Material : High Density PU
 Arms Colour : Yellow



CTG 20D
PULL DOWN

Product Code: 44812

Size (LxWxH) : 1110 x 1740 x 1990mm
Net Weight : 198 Kgs.
Steel Tubing : 50 x 100mm
Steel Thickness : 2.5mm
Frame Colour : Black
Seat Material : High Density PU
Arms Colour : Yellow

CTG 40D
REAR KICK

Product Code: 44816

Size (LxWxH) : 1115 x 1330 x 1650mm
Net Weight : 102 Kgs.
Steel Tubing : 50 x 100mm
Steel Thickness : 2.5mm
Frame Colour : Black
Seat Material : High Density PU
Arms Colour : Yellow



CTG 65D
SEATED DIP

Product Code: 44818

Size (LxWxH) : 1590 x 1385 x 970mm
Net Weight : 140 Kgs.
Steel Tubing : 50 x 100mm
Steel Thickness : 2.5mm
Frame Colour : Black
Seat Material : High Density PU
Arms Colour : Yellow

CANON-I PLATE LOADED



CTG 20 PULL DOWN

Product Code: 44802

Size (LxWxH) : 1810 x 1160 x 1925mm

Net Weight : 128 Kgs.

Steel Tubing : 60 x 120mm

Round Pipe(dia.) : 105mm

Steel Thickness : 3.0mm

Frame Colour : Black

Seat Material : PU with Once Forming
Technology

Arms Colour : Yellow

CTG 40

REAR KICK

Product Code: 44806

Size (LxWxH) : 1490 x 1130 x 1610 mm

Net Weight : 120 Kgs.

Steel Tubing : 60 x 120mm

Round Pipe(dia.) : 105mm

Steel Thickness : 3.0mm

Frame Colour : Black

Seat Material : PU with Once Forming
Technology

Arms Colour : Yellow





**CG-600****SIX STATION GYM**

Product Code: 44751

- Two Sets 70 Kgs **Steel Weight Stack**
- Dural Powder Coating Finish
- Pivot point on leg developer correctly align with knee joint for biomechanics
- 8mm Commercial Grade aircraft cables
- 104mm Pulley with commercial grade bearing
- 65mmx65mmx2.5mm and 60mmx60mmx2.0mm heavy duty construction tube
- Contoured ,deep padded seat and backrest

Max. User Weight : 150 Kgs.

Net Weight : 356 Kgs.

Assembly (LxWxH) : 3320 x 2440 x 2300mm

Function : Tricep Extension. Abdominal Crunch. Leg Extension & Leg Press, High Pull AB Crunch. Tricep Push-Down. Lat Pull Down, Bicep Curl. Pectoral Fly. Seated Press Bar Row, Preacher Curl, Bench Press, Leg Kick Back, Seated Shoulder Press , Dip ARM, Upright Row Standing Leg Curl, Standing Shoulder Knee, Raise & Dip Arm, Chin up, Sit up Dumbell Exercise, Lat Pull Bar And Ankle Strap , Power Tower.



CHG-408

FOUR STATION GYM

Product Code: 44815

• Four Sets 150lbs (600lbs) Weight Stacks

Max. User Weight : 150 Kgs.

Net Weight : 459 Kgs.

Assembly (LxWxH) : 2660 x 2470 x 2140 mm

Functions : Pec-dec, High pulley, Butterfly, Main body+VKR+Situp+Leg Press, Vertical Chest Press, Lat Pulldown, Leg Extension, Bicep, Tricep and Low Row.

**CG-125****FIVE STATION GYM****Product Code: 44752**

- Two Sets 145LBS Dead Weight Stacks filled concrete vinyl plates.
- Dual Powder Coating Finish
- Pivot point on leg developer correctly align with knee joint for biomechanics
- 2000lbs tensile strength aircraft cables
- 70x50mm heavy duty construction tube
- Contoured ,deep padded seat and backrest

Max. User Weight : 150 Kgs.

Net Weight : 270 Kgs.

Assembly (LxWxH) : 3140 x 2440 x 2300 mm

Functions : Tricep Extension Abdominal Crunch Leg Extension & Leg Press, High Pull, AB Crunch, Tricep Push-Down, Lat Pull Down, Bicep Curl, Pectoral Fly, Seated Press Bar Row, Preacher Curl Bench Press, Leg Kick Back, Seated Shoulder Press , Dip ARM Upright Row Standing Leg Curl, Standing Shoulder Knee Raise & Dip Arm Chin up, Sit up Dumbell Exercise with Lat Pull Bar And Ankle Strap , Power Tower.



Enhances strength of various muscle groups due to the versatile movements of its arms vertically and horizontally. It can follow almost any working movement. Pulleys are smooth and robust. Cables used are from USA. An open design makes it for all fitness levels. Handles moves independently.

CE 1801

TRANSFORM XT

DUAL CABLE CROSS

Product Code: 44514

Size(LxWxH) Minimum	: 1840 x 1080 x 1870 mm
Size(LxWxH) Maximum	: 1380 x 1600 x 2410 mm
Net Weight	: 350 Kgs.
Weight Plates	: 2 x 68 Kgs.
Steel Tubing	: 50 x 100 mm
Steel Thickness	: 2.5 mm
Weight Material	: Cast Iron
Cable	: 6 mm Dia.





CE 3016

ADJUSTABLE CROSSOVER

Product Code: 44512

- Size (LxWxH) : 4470 x 1090 x 2310 mm
- Net Weight : 396 Kgs.
- Weight Plates : 2 x 100 Kgs.
- Steel Tubing : 50 x 100 mm
- Steel Thickness : 2.5 mm
- Weight Material : Cast Iron
- Cable : 6 mm Dia.



CTB-15

ADJUSTABLE CROSSOVER

Product Code: 44003

- Size (LxWxH) : 4470 x 1090 x 2310 mm
- Net Weight : 396 Kgs.
- Weight Plates : 2 x 100 Kgs.
- Steel Tubing : 50 x 100 mm
- Steel Thickness : 2.5 mm
- Weight Material : Cast Iron
- Cable : 6 mm Dia.



CTB 89E

FUNCTIONAL TRAINER (3-in-1)
WITH RACK + SMITH MACHINE

Product Code: 44044

Size(LxWxH) : 2380 x 1940 x 2300 mm
 Net Weight : 480 Kgs.
 Weight Plates : 2 x 100 Kgs.



CE 1017

FUNCTIONAL TRAINER

Product Code: 44513

Size (LxWxH) : 1050 x 1760 x 2250 mm
 Net Weight : 345 Kgs.
 Weight Plates : 2 x 100 Kgs.
 Steel Tubing : 50 x 100 mm
 Steel Thickness : 2.5 mm
 Weight Material : Cast Iron
 Cable : 6 mm Dia.



DEGREE

XPC-0950A

FUNCTIONAL MACHINE (CABLE CROSS+SMITH MACHINE)

Product Code: 53251

Size (LxWxH) : 2351 x 1367 x 2159 mm
Net Weight : 260 Kgs.
Weight Plates : 128 Kgs.
Steel Tubing : 50 x 100 mm
Steel Thickness : 2.5 mm
Weight Material : Cast Iron
Cable : 6 mm Dia.

CTS 114

FUNCTIONAL TRAINER | SQUAT RACK | SMITH MACHINE

Product Code: 45104

Size (LxWxH) : 1800 x 2230x 2290 mm
Net Weight : 368 Kgs.
Steel Tubing : 80 x 50 mm
Steel Thickness : 3.0 mm (main)
Cushion : PU
Arms Colour : Yellow
Frame Colour : Black



XPL-202+ XPL-2002

HALF POWER RACK+ T-PLATFORM
(COMBINED DIMENSION)

Product Code: 53252

Size (LxWxH) : 3200 x 3200 x 2500 mm

Net Weight : 553 Kgs.

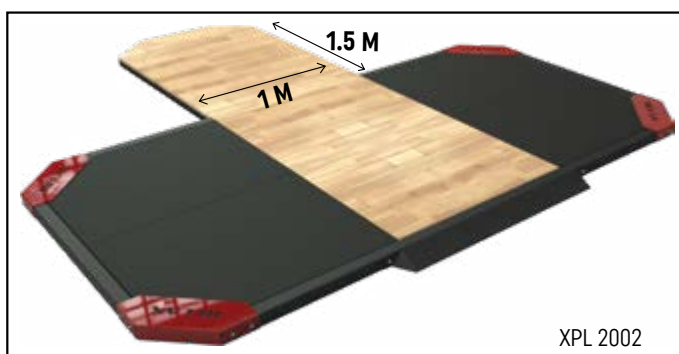

XPL 2002

XPL-2002

T-PLATFORM

Size (LxWxH) : 3200 x 3200 x 60 mm

Net Weight : 318 Kgs.

Steel Tubing : 60 x 60 mm

Steel Thickness : 3.0 mm



XPL-204

FULL POWER RACK

Product Code: 53254

Size (LxWxH) : 1400 x 2100 x 2500 mm

Net Weight : 351 Kgs.

Steel Tubing : 70 x 140 mm

Steel Thickness : 3.0 mm

XPL-202

HALF POWER RACK

Product Code: 53252

Size (LxWxH) : 1400 x 1500 x 2500 mm

Net Weight : 235 Kgs.

Steel Tubing : 70 x 140 mm

Steel Thickness : 3.0 mm



**CJN 2063B**

SMITH COMBO RACK WITH COUNTER BALANCE

Product Code: 44546

Size (LxWxH) : 1835 x 2210 x 2190 mm

Net Weight : 260 Kgs.

Steel Tubing : 50 x 100mm

Steel Thickness : 2.5mm

CE 6221

HALF RACK

Product Code: 44546

Size (LxWxH) : 1735x1800x2465 mm

Net Weight : 255 Kgs.

Steel Tubing : 50 x 100 mm

Steel Thickness : 2.5mm





CDZ-29

MULTI TRAINER

Product Code: 45102

Size (LxWxH) : 2195 x 1350 x 1620mm

Net Weight : 160 Kgs.



CAM 001

ELECTRIC GYM BED

Electric lift spa bed platform for massage. Platform can be adjusted to height of 300mm. Sturdy steel frame with high quality cushioning.

Product Code: 44567

Size (LxWxH) : 1900 x 720 x 600 mm

Net Weight : 100 Kgs.

**CTC 74****SHOULDER PRESS**

Product Code: 45103

Size (LxWxH) : 1400 x 1560 x 1660 mm

Net Weight : 176 Kgs.

Steel Tubing : 60 x 100 mm (Oval)

Steel Thickness : 4.0 mm

Seat : PU with Once Forming
Technology

Arms Colour : Yellow

Frame Colour : Black

**CTB-69****FORE ARM | WRIST CURL**

Product Code: 44033

Size (LxWxH) : 535 x 640 x 950mm

Weight Stack : 70 Kgs.

Net Weight : 110 Kgs.



CE 6248

DOUBLE STORAGE RACK

Product Code: 44610

Size (LxWxH) : 2750 x 490 x 2360 mm

Net Weight : 240 Kgs.



CE 6245

TRIPLE STORAGE RACK

Product Code: 44609

Size (LxWxH) : 4060 x 490 x 2360 mm

Net Weight : 393 Kgs.





DEGREE

PL 1006

LAT PULL DOWN PLATE LOADED

Product Code: 53256

Size (LxWxH) : 1725 x 1280 x 1980 mm

Net Weight : 184 Kgs.

CDZ-02

TYRE FLIP MACHINE

Product Code: 45100

Half tyre made for flipping in one spot. Training range can be increased by adding additional weight plates. Floor Mounting Points. Starting resistance of 72 Kgs. Plate loading ability up to 40 Addl. Kgs. 4 Sound Reducing Bumpers.

Size (LxWxH) : 1630 x 1220 x 580 mm

Net Weight : 145 Kgs.

Steel Tubing : 60 x 100 mm (Oval)

Steel Thickness : 4.0 mm

Arms Colour : Yellow

Frame Colour : Black



CRS-9

9 HOLE ROD STAND

Product Code: 45122

Size (LxWxH) : 1710 x 720 x 1450 mm

Net Weight : 35 Kgs.



DZ-61

MULTI FUNCTION BENCH (FID)

Product Code: 44045

Size (LxWxH) : 1570 x 680 x 490 mm

Net Weight : 52 Kgs.

ES-7011

MULTI BENCH (FI)

Product Code: 45108

Size (LxWxH) : 1440 x 525 x 489 mm

Net Weight : 34 Kgs.

Steel Tubing : 50 x 100 mm

Steel Thickness : 3.0 mm (main)



CJF

ABDOMINAL MACHINE COAST

Product Code: 45101

Size (LxWxH) : 1710 x 720 x 1450 mm

Net Weight : 35 Kgs.

Steel Tubing : 60 x 100 mm (Oval)

Steel Thickness : 4.0 mm

Seat : PU with Once Forming Technology

Arms Colour : Yellow

Frame Colour : Black



XTM-6404

CROSS FIT

Product Code: 50759

- Station : Over 8 stations
- Steel tube Thickness : 3.0mm
- Net Weight : 850 Kgs.
- Movement Area : 6000 x 5000mm
- Weight Plate : 2 x 100 Kgs.
- Size (LxWxH) : 4200 x 3200 x 2800mm



NITRO | MAGNUM

NON WEIGHT SERIES



CE 3036

FLAT BENCH

Product Code: 44526

Size (LxWxH) : 1410 x 680 x 420 mm
 Net Weight : 30 Kgs.
 Steel Tubing : 50 x 100mm
 Steel Thickness : 2.5mm

CE 3037

ADJUSTABLE DECLINE BECH

Product Code: 44527

Size (LxWxH) : 1640 x 680 x 990 mm
 Net Weight : 59 Kgs.
 Steel Tubing : 50 x 100mm
 Steel Thickness : 2.5mm



CE 3039

SUPER BENCH

Product Code: 44529

Size (LxWxH) : 1380 x 680 x 690 mm
 Net Weight : 43 Kgs.
 Steel Tubing : 50 x 100mm
 Steel Thickness : 2.5mm

CE 3038

MULTI-PURPOSE BENCH

Product Code: 44528

Size (LxWxH) : 1060 x 680 x 900 mm
 Net Weight : 35 Kgs.
 Steel Tubing : 50 x 100mm
 Steel Thickness : 2.5mm



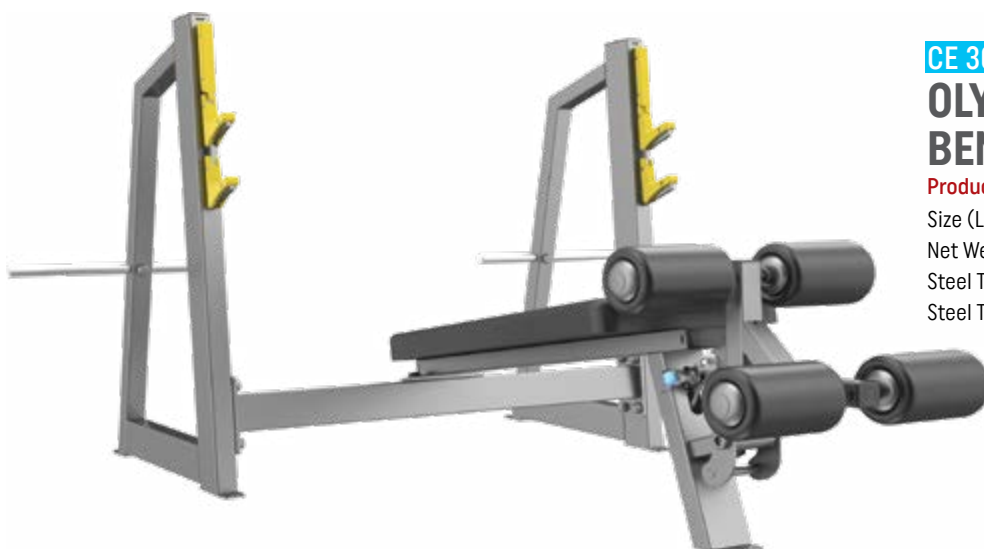

CE 3041

OLYMPIC DECLINE BENCH

Product Code: 44530

Size (LxWxH) : 2090 x 1700 x 1220 mm

Net Weight : 98 Kgs.

Steel Tubing : 50 x 100 mm

Steel Thickness : 2.5mm

CE 3042

OLYMPIC INCLINE BENCH

Product Code: 44531

Size (LxWxH) : 1960 x 1700 x 1400 mm

Net Weight : 127 Kgs.

Steel Tubing : 50 x 100 mm

Steel Thickness : 2.5mm



CE 3043

OLYMPIC FLAT BENCH

Product Code: 44532

Size (LxWxH) : 1740 x 1700 x 1220 mm

Net Weight : 94 Kgs.

Steel Tubing : 50 x 100 mm

Steel Thickness : 2.5mm



CE 3056**ANGLED LEG PRESS****Product Code: 44539**

Size (LxWxH) : 2210 x 1630 x 1350 mm

Net Weight : 266 Kgs.

Steel Tubing : 50 x 100 mm

Steel Thickness : 2.5mm

**CE 3057****HACK SQUAT****Product Code: 44540**

Size (LxWxH) : 2240x1260x1260 mm

Net Weight : 196 Kgs.

Steel Tubing : 50 x 100 mm

Steel Thickness : 2.5mm





CE 3065

SUPER SQUAT

Product Code: 44544

Size (LxWxH) : 2010 x 1630 x 1470 mm

Net Weight : 196 Kgs.

Steel Tubing : 50 x 100 mm

Steel Thickness : 2.5mm

CE 3062

SEATED CALF

Product Code: 44542

Size (LxWxH) : 1500x710x990 mm

Net Weight : 75 Kgs.

Steel Tubing : 50 x 100 mm

Steel Thickness : 2.5mm



CE 3082

AB TRAINER

Product Code: 44546

Size (LxWxH) : 1650 x 785 x 1465 mm

Net Weight : 80 Kgs.

Steel Tubing : 50 x 100mm

Steel Thickness : 2.5mm



CE 3063

SMITH MACHINE

Product Code: 44543

Size (LxWxH) : 1420 x 2210 x 2360 mm

Net Weight : 289 Kgs.

Steel Tubing : 50 x 100 mm

Steel Thickness : 2.5mm



CE 3048

POWER CAGE

Product Code: 44536

Size (LxWxH) : 1570 x 1240 x 2340 mm

Net Weight : 164 Kgs.

Steel Tubing : 50 x 100 mm

Steel Thickness : 2.5mm



CE 3047

VERTICAL KNEES UP | DIP

Product Code: 44535

Size (LxWxH) : 1270 x 710 x 1600 mm

Net Weight : 100 Kgs.

Steel Tubing : 50 x 100mm

Steel Thickness : 2.5mm

CE 3050

SQUAT RACK

Product Code: 44537

Size (LxWxH) : 1730 x 1700 x 1780 mm

Net Weight : 160 Kgs.

Steel Tubing : 50 x 100mm

Steel Thickness : 2.5mm



CE 3061

INCLINE LEVEL ROW

Product Code: 44541

Size (LxWxH) : 1850 x 790 x 1190 mm

Net Weight : 90 Kgs.

Steel Tubing : 50 x 100mm

Steel Thickness : 2.5mm



CE 3044

SEATED PREACHER CURL

Product Code: 44533

Size (LxWxH) : 1130 x 840 x 880 mm
 Net Weight : 54 Kgs.
 Steel Tubing : 50 x 100 mm
 Steel Thickness : 2.5mm

CE 3045

BACK EXTENSION

Product Code: 44534

Size (LxWxH) : 1210 x 890 x 670 mm
 Net Weight : 55 Kgs.
 Steel Tubing : 50 x 100 mm
 Steel Thickness : 2.5mm



CE 3077

DUMBBELL RACK (2 TIER)

Product Code: 44545

Size (LxWxH) : 720 x 2480 x 810 mm
 Net Weight : 26 Kgs.
 Steel Tubing : 50 x 100 mm
 Steel Thickness : 2.5mm

CE 3054

VERTICAL PLATE TREE

Product Code: 44538

Size (LxWxH) : 610 x 580 x 1240 mm
 Net Weight : 40 Kgs.
 Steel Tubing : 50 x 100 mm
 Steel Thickness : 2.5mm





CTB
NON WEIGHT SERIES



CTB-38
MULTI PURPOSE BENCH

Product Code: 44012
 Size (LxWxH) : 1200 x 670 x 820 mm
 Net Weight : 23 Kgs.
 Steel Tubing : 50 x 100mm
 Steel Thickness : 2.5mm



CTB-39
SUPER BENCH

Product Code: 44013
 Size (LxWxH) : 1400 x 670 x 440 mm
 Net Weight : 38 Kgs.
 Steel Tubing : 50 x 100mm
 Steel Thickness : 2.5mm

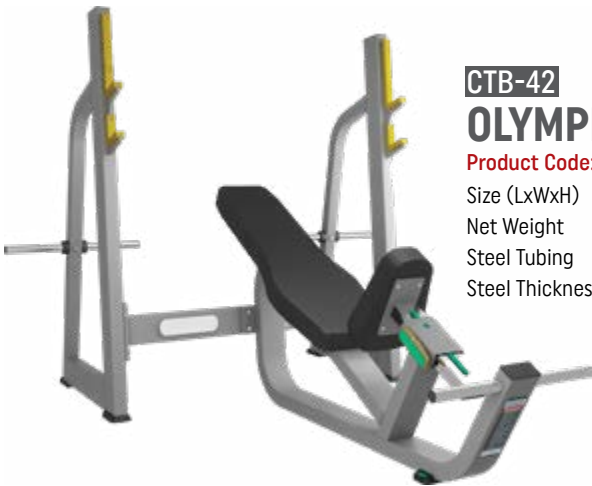

CTB-42
OLYMPIC INCLINE BENCH

Product Code: 44015
 Size (LxWxH) : 1980 x 1660 x 1400 mm
 Net Weight : 77 Kgs.
 Steel Tubing : 50 x 100mm
 Steel Thickness : 2.5mm



CTB-43
OLYMPIC FLAT BENCH

Product Code: 44016
 Size (LxWxH) : 1670 x 1660 x 1230 mm
 Net Weight : 61 Kgs.
 Steel Tubing : 50 x 100mm
 Steel Thickness : 2.5mm



CTB-86
**FLAT | INCLINE |
DECLINE BENCH (3 in 1)**

Product Code: 44028
 Bench Size (LxWxH) : 1040 x 1730 x 1390 mm
 Stand Size (LxWxH) : 1600 x 760 x 580 mm
 Net Weight : 140 Kgs.



CTB-87
SMITH WITH HACK SQUAT

Product Code: 44029

Size (LxWxH) : 2351 x 1367 x 2159 mm
Net Weight : 128 Kgs.
Steel Tubing : 50 x 100 mm
Steel Thickness : 2.5 mm
Weight Material : Cast Iron
Cable : 6 mm Dia.

CTB-63
SMITH MACHINE

Product Code: 44025

Size (LxWxH) : 1450 x 2200 x 2200 mm
Net Weight : 284 Kgs.
Steel Tubing : 50 x 100mm
Steel Thickness : 2.5mm



CTB-48
POWER CAGE

Product Code: 44020

Size (LxWxH) : 1480 x 1330 x 2290 mm
Net Weight : 131 Kgs.
Steel Tubing : 50 x 100mm
Steel Thickness : 2.5mm



CTB-47
VERTICAL KNEES UP | DN

Product Code: 44019

Size (LxWxH) : 1170 x 750 x 1600 mm

Net Weight : 69 Kgs.

Steel Tubing : 50 x 100mm

Steel Thickness : 2.5mm

CTB-50
SQUAT RACK

Product Code: 44021

Size (LxWxH) : 1780 x 1680 x 1790 mm

Net Weight : 111 Kgs.

Steel Tubing : 50 x 100mm

Steel Thickness : 2.5mm



CTB-67
BEAUTY DUMBBELL (3 TIER)

Product Code: 44027

Size (LxWxH) : 1445 x 650 x 1015 mm

Net Weight : 69 Kgs.

Steel Tubing : 50 x 100mm

Steel Thickness : 2.5mm



DZ-61
MULTI FUNCTION BENCH (FID)

Product Code: 44045

Size (LxWxH) : 1570 x 680 x 490 mm

Net Weight : 52 Kgs.

CTB-61
INCLINE LEVEL ROW

Product Code: 44023

Size (LxWxH) : 1800 x 1000 x 1160 mm

Net Weight : 60 Kgs.

Steel Tubing : 50 x 100mm

Steel Thickness : 2.5mm



CTB-45
BACK EXTENSION

Product Code: 44018

Size (LxWxH) : 1130 x 900 x 750 mm

Net Weight : 45 Kgs.

Steel Tubing : 50 x 100mm

Steel Thickness : 2.5mm

CTB-44
SEATED PREACHER CURL

Product Code: 44017

Size (LxWxH) : 1340 x 780 x 940 mm

Net Weight : 46 Kgs.

Steel Tubing : 50 x 100mm

Steel Thickness : 2.5mm





CTB-56
45° LEG PRESS

Product Code: 44041

Size (LxWxH) : 2190 x 1640 x 1260 mm
 Net Wt. : 215 Kgs.
 Steel Tubing : 50 x 100 mm
 Steel Thickness : 2.5 mm



CTB-65
SUPER SQUAT

Product Code: 44026

Size (LxWxH) : 1990 x 1640 x 1450 mm
 Net Weight : 196 Kgs.
 Steel Tubing : 50 x 100mm
 Steel Thickness : 2.5mm



CTB-59
LEG PRESS | HACK SQUAT

Product Code: 44008

Size (LxWxH) : 2420 x 1610 x 1450 mm
 Net Wt. : 249 Kgs.
 Steel Tubing : 50 x 100 mm
 Steel Thickness : 2.5 mm



CTB-62
SEATED CALF

Product Code: 44024

Size (LxWxH) : 1460 x 600 x 1015 mm

Net Weight : 53 Kgs.

Steel Tubing : 50 x 100mm

Steel Thickness : 2.5mm

CTB-70
AB CRUNCH

Product Code: 44038

Size (LxWxH) : 1530 x 890 x 980 mm

Net Weight : 60 Kgs.

Steel Tubing : 50 x 100mm

Steel Thickness : 2.5mm



CTB-71
STRETCH MACHINE

Product Code: 44039

Size (LxWxH) : 1450 x 520 x 1150 mm

Net Weight : 46 Kgs.

Steel Tubing : 50 x 100mm

Steel Thickness : 2.5mm

CTB-92
SISSY SQUAT

Product Code: 44039

Size (LxWxH) : 1005 x 560 x 510 mm

Net Weight : 42 Kgs.

Steel Tubing : 60 x 100mm (Oval)

Steel Thickness : 3.0mm



ELITE

NON WEIGHT SERIES



CU 3056B

ANGLED LEG PRESS

Product Code: 44587

Size (LxWxH) : 2170 x 1610 x 1260 mm

Net Weight : 243 Kgs.

Steel Tubing : 50 x 100mm

Steel Thickness : 2.5mm

CU 3061B

INCLINE LEVEL ROW

Product Code: 44589

Size (LxWxH) : 1850 x 790 x 1190 mm

Net Weight : 74 Kgs.

Steel Tubing : 50 x 100mm

Steel Thickness : 2.5mm



CU 3057B

HACK SQUAT

Product Code: 44588

Size (LxWxH) : 2230 x 1630 x 1270 mm

Net Weight : 183 Kgs.

Steel Tubing : 50 x 100mm

Steel Thickness : 2.5mm



CU 3063B

SMITH MACHINE

Product Code: 44591

Size (LxWxH) : 1090 x 2180 x 2320 mm

Net Weight : 258 Kgs.

Steel Tubing : 50 x 100mm

Steel Thickness : 2.5mm

CJN 2063B

SMITH COMBO RACK
(SMITH MACHINE + SQUAT RACK)

Product Code: 44592

Size (LxWxH) : 1835 x 2210 x 2190 mm

Net Weight : 260 Kgs.

Steel Tubing : 50 x 100mm

Steel Thickness : 2.5mm



CU 3062B

SEATED CALF

Product Code: 44590

Size (LxWxH) : 1500 x 710 x 990 mm

Net Weight : 57 Kgs.

Steel Tubing : 50 x 100mm

Steel Thickness : 2.5mm





CJN 2036B

FLAT BENCH

Product Code: 44593

Size (LxWxH) : 1270 x 610 x 412 mm
 Net Weight : 14 Kgs.
 Steel Tubing : 50 x 100mm
 Steel Thickness : 2.5mm

CJN 2037B

ADJUSTABLE DECLINE BENCH

Product Code: 44594

Size (LxWxH) : 1685 x 685 x 685 mm
 Net Weight : 31 Kgs.
 Steel Tubing : 50 x 100mm
 Steel Thickness : 2.5mm



CJN 2038B

MULTI PURPOSE BENCH

Product Code: 44595

Size (LxWxH) : 860 x 686 x 795 mm
 Net Weight : 14 Kgs.
 Steel Tubing : 50 x 100mm
 Steel Thickness : 2.5mm

CJN 2039B

SUPER BENCH

Product Code: 44596

Size (LxWxH) : 1330 x 686 x 455 mm
 Net Weight : 25 Kgs.
 Steel Tubing : 50 x 100mm
 Steel Thickness : 2.5mm





CJN 2041B

OLYMPIC DECLINE BENCH

Product Code: 44597

Size (LxWxH) : 2060 x 1780 x 1090 mm

Net Weight : 50 Kgs.

Steel Tubing : 50 x 100mm

Steel Thickness : 2.5mm

CJN 2042B

OLYMPIC INCLINE BENCH

Product Code: 44598

Size (LxWxH) : 1730 x 1775 x 1405 mm

Net Weight : 57 Kgs.

Steel Tubing : 50 x 100mm

Steel Thickness : 2.5mm



CJN 2043B

OLYMPIC FLAT BENCH

Product Code: 44599

Size (LxWxH) : 1690 x 1775 x 1235 mm

Net Weight : 46 Kgs.

Steel Tubing : 50 x 100mm

Steel Thickness : 2.5mm





CJN 2044B

SEATED PREACHER CURL

Product Code: 44600

Size (LxWxH) : 1235 x 1225 x 945 mm

Net Weight : 32 Kgs.

Steel Tubing : 50 x 100mm

Steel Thickness : 2.5mm

CJN 2045B

BACK EXTENSION

Product Code: 44601

Size (LxWxH) : 1210 x 885 x 650 mm

Net Weight : 33 Kgs.

Steel Tubing : 50 x 100mm

Steel Thickness : 2.5mm



CJN 2047B

VERTICAL KNEES DIP/UP

Product Code: 44602

Size (LxWxH) : 1140 x 750 x 1590 mm

Net Weight : 44 Kgs.

Steel Tubing : 50 x 100mm

Steel Thickness : 2.5mm



CU 3070B

ABDOMINAL TRAINER

Product Code: 44606

Size (LxWxH) : 1540 x 920 x 1030 mm

Net Weight : 68 Kgs.

Steel Tubing : 50 x 100mm

Steel Thickness : 2.5mm

NON WEIGHT MACHINES



CU 3077B

2 TIER DUMBBELL RACK

Product Code: 44605

Size (LxWxH) : 720 x 2480 x 810 mm

Net Weight : 68 Kgs.

Steel Tubing : 50 x 100mm

Steel Thickness : 2.5mm



CU 3067B

3 TIER DUMBBELL RACK

Product Code: 44604

Size (LxWxH) : 1450 x 650 x 1000 mm

Net Weight : 75 Kgs.

Steel Tubing : 50 x 100mm

Steel Thickness : 2.5mm

CU 3054B

VERTICAL PLATE TREE

Product Code: 44603

Size (LxWxH) : 610 x 580 x 1240 mm

Net Weight : 30 Kgs.

Steel Tubing : 50 x 100mm

Steel Thickness : 2.5mm



CU 3071B

STRETCH TRAINER

Product Code: 44607

Size (LxWxH) : 1430 x 530 x 1210 mm

Net Weight : 52 Kgs.

Steel Tubing : 50 x 100mm

Steel Thickness : 2.5mm



CU 6236B

8 BARBELL STORAGE BASE

Product Code: 44608

Size (LxWxH) : 740 x 670 x 210 mm

Net Weight : 35 Kgs.

Steel Tubing : 50 x 100mm

Steel Thickness : 2.5mm



CFE
SINGLE STATION



CFE 9710
LEG PRESS

Product Code: 43005

- Size (LxWxH) : 1785 x 1350 x 1490 mm
- Net Weight : 279 Kgs.
- Weight Plates : 235 lbs
- Steel Tubing : 72.8 x 141.7mm
- Steel Thickness : 3.0mm
- Pulley | Material : Dia. 114mm | MS
- Weight Material : 19 mm Full Steel
Each plate weight 10 lbs
- Cable : 5 mm Dia.

CFE 9702

LAT PULL DOWN

Product Code: 43001

- Size (LxWxH) : 1305 x 1230 x 2010 mm
- Net Weight : 177 Kgs.
- Weight Plates : 235 lbs
- Steel Tubing : 72.8 x 141.7mm
- Steel Thickness : 3.0mm
- Pulley | Material : Dia. 114mm | MS
- Weight Material : 19 mm Full Steel
Each plate weight 10 lbs
- Cable : 5 mm Dia.



CFE 9720

WT. ASSISTED CHIN | DIP COMBO

Product Code: 43009

- Size (LxWxH) : 1750 x 1380 x 2200 mm
- Net Weight : 243 Kgs.
- Weight Plates : 235 lbs
- Steel Tubing : 72.8 x 141.7mm
- Steel Thickness : 3.0mm
- Pulley | Material : Dia. 114mm | MS
- Weight Material : 19 mm Full Steel
Each plate weight 10 lbs
- Cable : 5 mm Dia.



CFE 9703
ARM CURL

Product Code: 43002

Size (LxWxH) : 1150 x 1567 x 1490 mm
 Net Weight : 169 Kgs.
 Weight Plates : 235 lbs
 Steel Tubing : 72.8 x 141.7mm
 Steel Thickness : 3.0mm
 Pulley | Material : Dia. 114mm | MS
 Weight Material : 19 mm Full Steel
 Each plate weight 10 lbs
 Cable : 5 mm Dia.

CFE 9705
LEG EXTENSION

Product Code: 43003

Size (LxWxH) : 1300 x 1240 x 1490 mm
 Net Weight : 169 Kgs.
 Weight Plates : 235 lbs
 Steel Tubing : 72.8 x 141.7mm
 Steel Thickness : 3.0mm
 Pulley | Material : Dia. 114mm | MS
 Weight Material : 19 mm Full Steel
 Each plate weight 10 lbs
 Cable : 5 mm Dia.



CFE 9706
SEATED LEG CURL

Product Code: 43004

Size (LxWxH) : 1242 x 1541 x 1490 mm
 Net Weight : 183 Kgs.
 Weight Plates : 235 lbs
 Steel Tubing : 72.8 x 141.7mm
 Steel Thickness : 3.0mm
 Pulley | Material : Dia. 114mm | MS
 Weight Material : 19 mm Full Steel
 Each plate weight 10 lbs
 Cable : 5 mm Dia.



CFE 9712
SHOULDER PRESS

Product Code: 43006

Size (LxWxH) : 1385 x 1210 x 1490 mm
 Net Weight : 141 Kgs.
 Weight Plates : 235 lbs
 Steel Tubing : 72.8 x 141.7mm
 Steel Thickness : 3.0mm
 Pulley | Material : Dia. 114mm | MS
 Weight Material : 19 mm Full Steel
 Each plate weight 10 lbs
 Cable : 5 mm Dia.

CFE 9715
PEC FLY | REAR DELT

Product Code: 43007

Size (LxWxH) : 1296 x 1758 x 1490 mm
 Net Weight : 160 Kgs.
 Weight Plates : 235 lbs
 Steel Tubing : 72.8 x 141.7mm
 Steel Thickness : 3.0mm
 Pulley | Material : Dia. 114mm | MS
 Weight Material : 19 mm Full Steel
 Each plate weight 10 lbs
 Cable : 5 mm Dia.



CFE 9719
ROW

Product Code: 43008

Size (LxWxH) : 2000 x 1130 x 1490 mm
 Net Weight : 174 Kgs.
 Weight Plates : 235 lbs
 Steel Tubing : 72.8 x 141.7mm
 Steel Thickness : 3.0mm
 Pulley | Material : Dia. 114mm | MS
 Weight Material : 19 mm Full Steel
 Each plate weight 10 lbs
 Cable : 5 mm Dia.

CIE
NON WEIGHT**CIE 7001B****SMITH MACHINE**

Product Code: 43010

Size (LxWxH) : 2241 x 1326 x 2370 mm

Net Weight : 178 Kgs.

Steel Tubing : 100 x 50mm (Racetrack Tubing)

Steel Thickness : 2.75 ~ 2.5mm

CIE 7006C**LEG PRESS | HACK SQUAT**

Product Code: 43013

Size (LxWxH) : 2253 x 975 x 1475 mm

Net Weight : 166 Kgs.

Steel Tubing : 100 x 50mm (Racetrack Tubing)

Steel Thickness : 2.75 ~ 2.5mm





CIE 7004B

STRETCH

Product Code: 43012

Size (LxWxH) : 1274 x 552 x 997 mm

Net Weight : 35 Kgs.

Steel Tubing : 100 x 50mm (RacetrackTubing)

Steel Thickness : 2.75 ~ 2.5mm

CIE 7003C

AB CRUNCH

Product Code: 43011

Size (LxWxH) : 1745 x 936 x 997 mm

Net Weight : 57 Kgs.

Steel Tubing : 100 x 50mm (Racetrack Tubing)

Steel Thickness : 2.75 ~ 2.5mm



CIE 7009B

FLAT BENCH

Product Code: 43015

Size (LxWxH) : 1200 x 781 x 1515mm

Net Weight : 53 Kgs.

Steel Tubing : 100 x 50mm (Racetrack Tubing)

Steel Thickness : 2.75 ~ 2.5mm

CIE 7007B

MULTI-HYPER EXT.

Product Code: 43014

Size (LxWxH) : 1312 x 749 x 914 mm

Net Weight : 43 Kgs.

Steel Tubing : 100 x 50mm (Racetrack Tubing)

Steel Thickness : 2.75 ~ 2.5mm





CIE 7011C
MULTI-ADJ. BENCH

Product Code: 43016

Size (LxWxH) : 1212 x 750 x 465 mm
 Net Weight : 40 Kgs.
 Steel Tubing : 100 x 50mm (Racetrack Tubing)
 Steel Thickness : 2.75 ~ 2.5mm

CIE 7014B
FLAT BENCH PRESS

Product Code: 43017

Size (LxWxH) : 1657 x 1658 x 1373 mm
 Net Weight : 82 Kgs.
 Steel Tubing : 100 x 50mm (Racetrack Tubing)
 Steel Thickness : 2.75 ~ 2.5mm



CIE 7015C
INCLINE BENCH PRESS

Product Code: 43018

Size (LxWxH) : 1632 x 1658 x 1373 mm
 Net Weight : 106 Kgs.
 Steel Tubing : 100 x 50mm (Racetrack Tubing)
 Steel Thickness : 2.75 ~ 2.5mm



CIE 7017C
WEIGHT PLATE TREE

Product Code: 43019

Size (LxWxH) : 950 x 610 x 1220 mm
 Net Weight : 26 Kgs.
 Steel Tubing : 100 x 50mm (Racetrack Tubing)
 Steel Thickness : 2.75 ~ 2.5mm





CS
NON WEIGHT



CS1
FLAT BENCH (IFFB)

Product Code: 44273

Size (LxWxH) : 1300 x 520 x 490 mm
 Net Weight : 20 Kgs.
 Steel Tubing : 51 x 76mm
 Steel Thickness : 2.5mm

CS2
HYPER EXTENSION BENCH (IF45)

Product Code: 44274

Size (LxWxH) : 1300 x 520 x 490 mm
 Net Weight : 23 Kgs.
 Steel Tubing : 51 x 76mm
 Steel Thickness : 2.5mm



CS3
MULTI-PURPOSE BENCH (IFFID)

Product Code: 44275

Size (LxWxH) : 1580 x 650 x 510 mm
 Net Weight : 33 Kgs.
 Steel Tubing : 51 x 76mm
 Steel Thickness : 2.5mm



CS16
ADJ.ABDOMINAL BENCH (IFAAB)

Product Code: 44266

Size (LxWxH) : 1680 x 560 x 1140 mm
 Net Weight : 24 Kgs.
 Steel Tubing : 51 x 76mm
 Steel Thickness : 2.5mm





CS4
OLYMPIC FLAT BENCH PRESS (IFOFB)

Product Code: 44277

Size (LxWxH) : 1520 x 1310 x 1260 mm

Net Weight : 60 Kgs.

Steel Tubing : 51 x 76mm

Steel Thickness : 2.5mm

CS5
OLYMPIC INCLINE BENCH PRESS (IFOIB)

Product Code: 44278

Size (LxWxH) : 1560 x 1310 x 1190 mm

Net Weight : 68 Kgs.

Steel Tubing : 51 x 76mm

Steel Thickness : 2.5mm



CS6
OLYMPIC DECLINE BENCH PRESS (IFODB)

Product Code: 44279

Size (LxWxH) : 1900 x 1310 x 1150 mm

Net Weight : 70 Kgs.

Steel Tubing : 51 x 76mm

Steel Thickness : 2.5mm





CS7

OLYMPIC BENCH (IFOB)

Product Code: 44265

Size (LxWxH) : 1430 x 1260 x 1460 mm

Net Weight : 62 Kgs.

Steel Tubing : 51 x 76mm

Steel Thickness : 2.5mm



CS8

SEATED ARM CURL (IFSPC)

Product Code: 44268

Size (LxWxH) : 1020 x 710 x 890 mm

Net Weight : 24 Kgs.

Steel Tubing : 51 x 76mm

Steel Thickness : 2.5mm



CS10

AB | BACK MACHINE (IFABM)

Product Code: 44269

Size (LxWxH) : 1520 x 1000 x 1060 mm

Net Weight : 38 Kgs.

Steel Tubing : 51 x 76mm

Steel Thickness : 2.5mm

CS11

LEG EXTENTION | CURL (IFLEGM)

Product Code: 44270

Size (LxWxH) : 1210 x 1040 x 1040 mm

Net Weight : 51 Kgs.

Steel Tubing : 51 x 76mm

Steel Thickness : 2.5mm





CS13
SMITH MACHINE W | LINEAR BEARING (IFHC+IFHCS)

Product Code: 44271

Size (LxWxH) : 1960 x 1720 x 2090 mm

Net Weight : 133 Kgs.

Steel Tubing : 51 x 76mm

Steel Thickness : 2.5mm

CS15
BEAUTY BELL RACK (IFDB4+IFDB4A)

Product Code: 44280

Size (LxWxH) : 1370 x 1470 x 860 mm

Net Weight : 47 Kgs.

Steel Tubing : 51 x 76mm

Steel Thickness : 2.5mm



CS14
LEG PRESS | HACK SQUAT (IFLPHS)

Product Code: 44272

Size (LxWxH) : 2500 x 800 x 1500 mm

Net Weight : 145 Kgs.

Steel Tubing : 51 x 76mm

Steel Thickness : 2.5mm



YL-03L

ADJUSTBLE DUMBBELL

Product Code: 28936

Weight Range : 2-32 Kgs.

Net Weight : 32 Kgs.



YL-02L

ADJUSTBLE DUMBBELL

Product Code: 28935

Weight Range : 2-20 Kgs.

Net Weight : 20 Kgs.



YL-03L+BTL

2x32 Kgs. DUMBBELL WITH 1 RACK

Product Code: 28927

Net Weight : 74 Kgs.



YL-02L+BTL

2x20 Kgs. DUMBBELL WITH 1 RACK

Product Code: 28937

Net Weight : 50 Kgs.





cosco.in



DELHI | GURUGRAM | JALANDHAR | MUMBAI

Cosco (India) Limited

2/8 Roop Nagar, Delhi-110007

Tel. : +91 11 41849999, 23843000 | E-mail: mail@cosco.in

FOLLOW US ON SOCIAL MEDIA

